



WAARDENBURG
MEDICAL

ALVO[®]
MEDICAL



FURNITURE AND MEDICAL EQUIPMENT



Make sure your working environment is ergonomic



From large regional hospitals catering for the latest surgical techniques to small local hospital facilities planning step-by-step development, our customers face the same challenge: making their operating rooms (OR) really ergonomic. Modular and open-architecture solutions are needed.

- Easy to install and maintain
- Future-proof architecture
- Possible to develop or add onto existing system

- Holistic approach to designing operating rooms and other hospital areas in order to support cleaning procedures and enhance hygiene
- Eliminating cable clutter, clash of technologies and providing optimal workflow

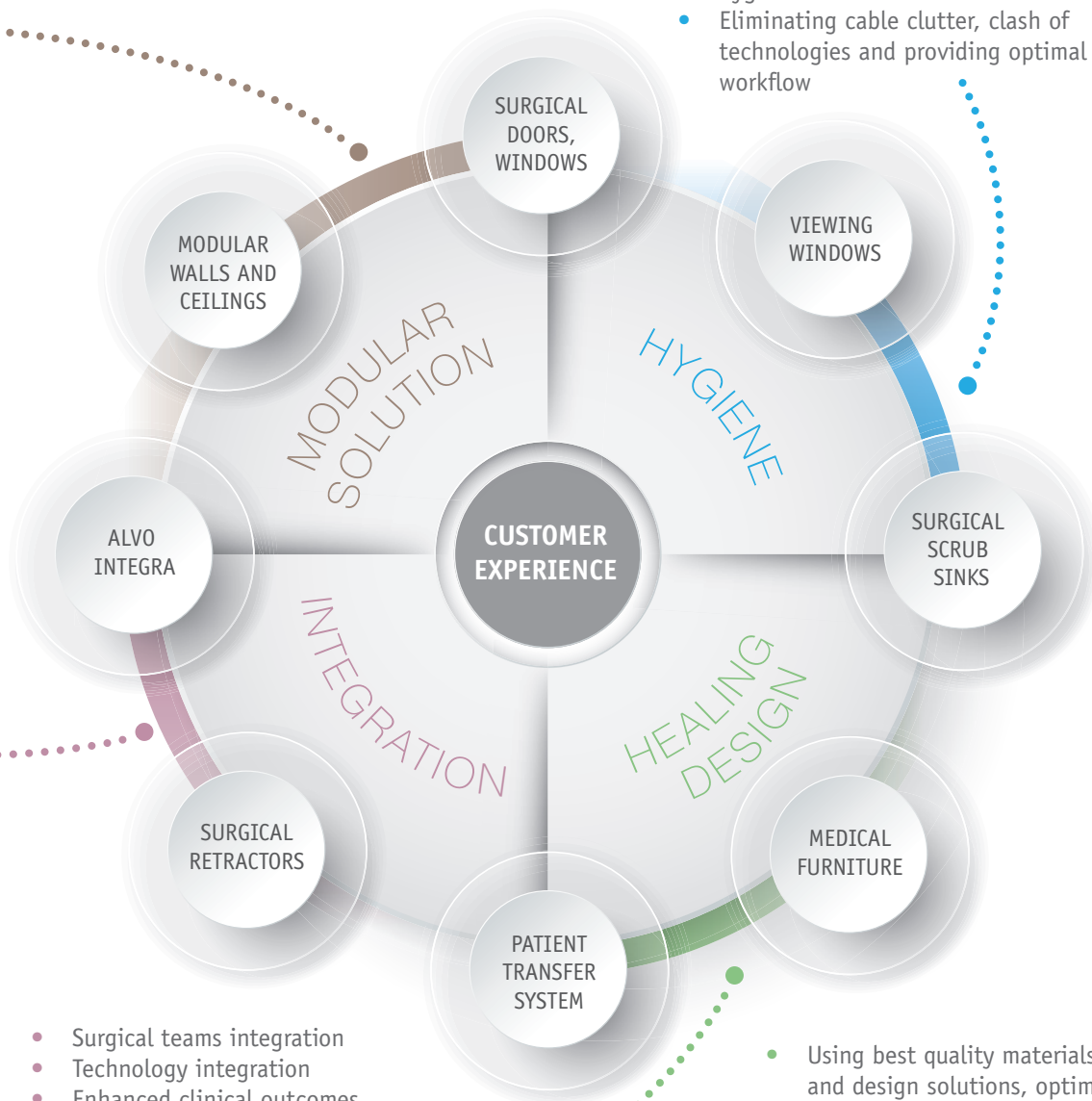

- Surgical teams integration
- Technology integration
- Enhanced clinical outcomes through proper access to patient's data

- Using best quality materials and design solutions, optimizing lights parameters in the room
- Modular technology with storage cabinets and monitors built into the walls saves space and gives modern and prestigious look

ALVO customer experience centers

Unique value proposition

In our global medical training centers, users and planners can work together with Dräger and ALVO experts to plan and design their medical workplaces under realistic conditions.

Surgical teams can experience how easy and quick it is to set-up their OR for surgery in a completely integrated video-over-IP environment. This user involvement not only increases acceptance levels, but also opens projects to new ideas.



ALVO Integra Center
21 A Południowa Street
64-030 Śmigiel, **POLAND**

Cadolto fertigggebäude
GMBH & CO. KG
Wachendorfer Straße 34
Cadolzburg, **GERMANY**

Dräger Design Center
Al Malaz Al Ehsa Street
Riyadh, **SAUDI ARABIA**

over **250** employees
in ALVO headquarters
in Poland

over **20** years
of experience

over **50** countries
in our reference list

over **74** thousand
of square meters in modular
solutions installed

Contact us to find out about current
Planner's Events: marketing@alvo.pl













Dräger Design Center
Dräger Medical GmbH
Branch Office
P.O. Box 505108
Dubai, **UAE**

**Dräger Design Center
South Africa**
Dräger Medical
South Africa (Pty) Ltd.
PO Box 4676, Rivonia, 2128
REPUBLIC OF SOUTH AFRICA

Dräger Design Center
Dräger Medical
India Pvt. Ltd.
Link Road, Malad (West)
400 064 Mumbai, **INDIA**

**Simonsen&Weel
Design Center**
Vejlegårdsvej 59
DK-2665 Vallensbæk Strand
DENMARK



MODULAR FURNITURE SYSTEM	8	
SURGICAL SINKS	14	
INSTRUMENT TABLES	22	
ANESTHESIA AND EMERGENCY TROLLEYS	28	
EQUIPMENT FOR OPERATING ROOMS	38	
TROLLEYS FOR MEDICAL DEVICES	48	
TROLLEYS FOR LINEN TRANSPORTATION	54	
MEDICAL AND STORAGE CABINETS	60	
BASKETS, SHELVES AND TROLLEYS FOR STERILE PRODUCTS	80	
MEDICAL WORKING TABLES	92	
COUCHES AND BED SCREENS	102	

01
MODULAR
FURNITURE
SYSTEM



The ALVO modular furniture system was designed with the needs of medical staff in mind, taking into account the demands of our customers and guaranteeing the highest standards of hygiene, functionality and ergonomics—but also comfort and safety during use. ALVO's modular medical furnishings are characterized by a user-friendly design and delicate contours, allowing limitless possibilities for customization and ensuring the optimal utilization of hospital space. Keeping in mind the specialized demands of the health sector, the ALVO modular furnishing line ensures the best utilization of internal cabinetry space, offering a wide range of practical solutions matched to the needs of our customers and allowing for individual interior design by the user.



01

MODULAR FURNITURE SYSTEM

The modular furniture system by ALVO offers various types of high cabinets, low cabinets, suspended cabinetry, cabinetry extensions, tables and tables with embedded sinks. From this wide range of products our customers are able to design interiors for many purposes, choosing specifications as detailed as the number of shelves and drawers according to individual needs.

Furnishings are made from durable, grade 1.4301 stainless steel or powder-coated sheet steel, painted from one of the colors of the ALVO RAL palette.

The antimicrobial protection based on Sanitized® technology ensures the best protection against bacterias in all the powder coated surfaces. In addition, the fittings and other touch surfaces can be made of antimicrobial copper Cu+ under request.

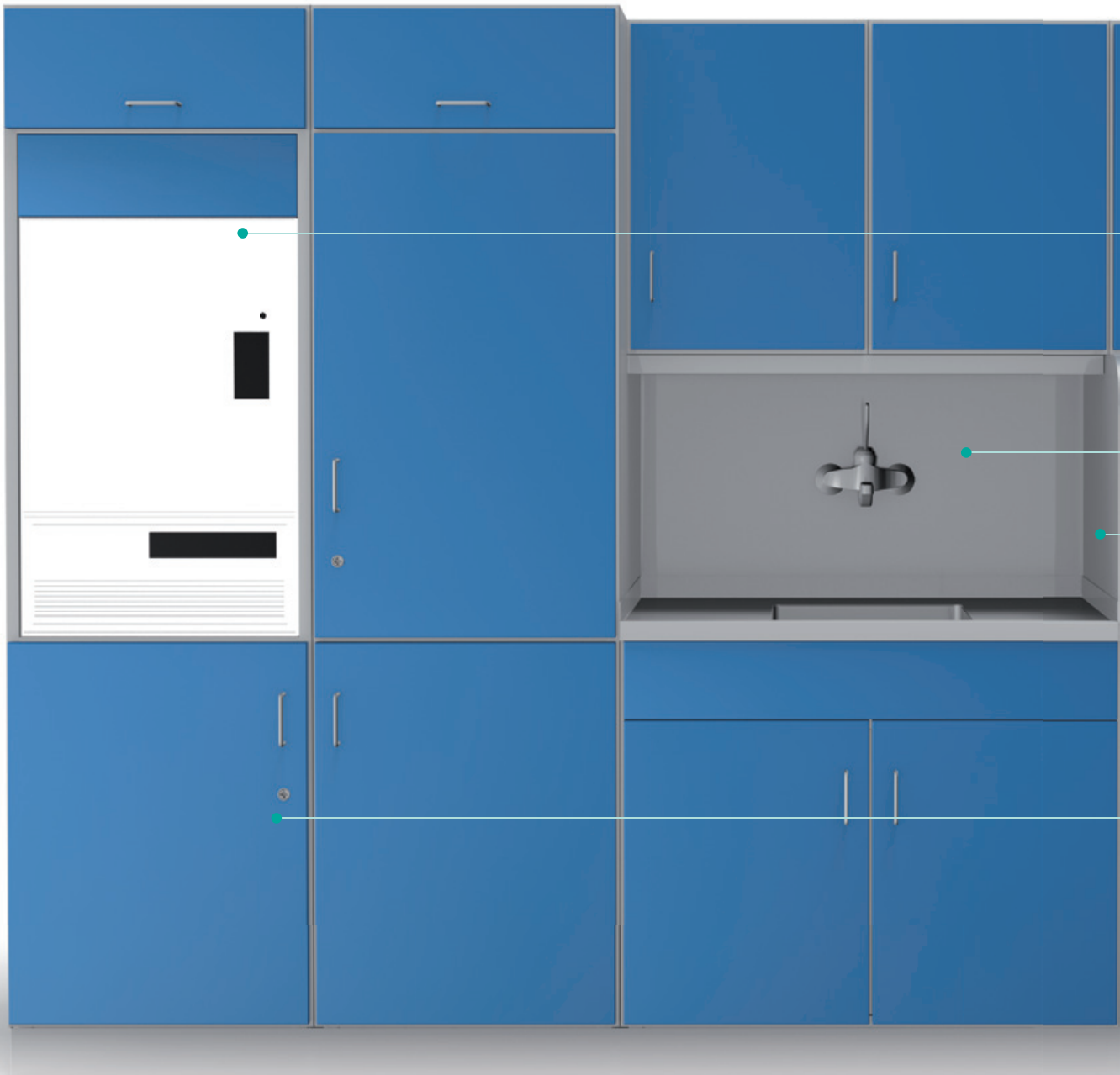

Table and counter tops can be constructed of stainless steel, mineral-acrylic materials (Corian, Staron), medium-density fiberboard (MDF) or high-pressure laminate (HPL). In addition, furnishings can be fitted with made to measure stainless steel or powder-coated sheet steel trims. These trims serve to cover any given space between furnishings and walls or furnishings and ceiling. Thanks to the wide availability of accessories (including bins and hangers from the Scan Module Line), the ergonomic and optimal utilization of interior cabinet space is guaranteed.



DRUG REFRIGERATOR

TABLE TOP LIGHTING

STAINLESS STEEL WALL PANEL

SPLASH GUARD

LOCKED CABINET FOR DRUGS

HEATED DRAWER





STEEL TRIM

DRUG REFRIGERATOR

FLAT STAINLESS STEEL TABLE TOP

LOCKED CABINET





02

SURGICAL SINKS



ALVO surgical sinks are made of the highest quality stainless steel 1.4301, and selected designs are made of mineral composite materials (eg. Corian, Staron). The surgical scrubs are designed for operating theatres and other facilities where highest hygienic standards have to be maintained.

MAIN FEATURES:

As standard products we offer sinks with single, double and triple bays; free standing and wall hanging. We offer a wide range of options, such as knee operated or infrared water tap and soap dispensers. Additional accessories such as touchless and elbow operated faucets, brush and paper towel dispensers can also be ordered.



02

SURGICAL SINKS



2-090
Surgical sink

- made of stainless steel 1.4301
- wall mounted scrub sink
- depth of sink: 200 mm
- drain traps included
- additional accessories mounted to the wall available: water taps, soap and disinfectant dispensers, brush dispensers and paper towels dispensers, basket
- available with ALVO CleanDrains siphon

	L	S	H	
2-090-1	845	520	440	single bay
2-090-2	1600	520	440	double bay
2-090-3	2355	520	440	triple bay



2-091
Surgical sink with wall panel

- made of stainless steel 1.4301
- wall mounted scrub sink
- scrub sink with wall panel
- depth of sink: 200 mm
- drain traps included
- additional accessories mounted to the wall available: water taps, soap and disinfectant dispensers, brush dispensers and paper towels dispensers
- available with ALVO CleanDrains siphon

	L	S	H	
2-091-1	845	600	1240	single bay
2-091-2	1600	600	1240	double bay
2-091-3	2355	600	1240	triple bay



2-092
Surgical sink with knee operated soap dispenser and knee operated water tap

- made of stainless steel 1.4301
- free standing sink with wall mounting possibility
- depth of sink: 300 mm
- standard: drain traps included; knee activated water and soap dispensers; water and soap time adjustable (0,25 s - 12 min); adjustable water temperature (35°C - 41°C); chrome faucets
- additional accessories mounted to the wall available: water taps, soap and disinfectant dispensers, brush dispensers and paper towels dispensers
- available with ALVO CleanDrains siphon

	L	S	H	
2-092-1	845	635	1170	single bay
2-092-2	1600	635	1170	double bay
2-092-3	2355	635	1170	triple bay



2-093

Surgical sink with infrared soap dispenser and infrared water tap

- made of stainless steel 1.4301
- free standing sink with wall mounting possibility
- depth of sink: 300 mm
- the front panel of the scrub sink can be opened, lockable with 2 bolts
- standard: drain traps included; water and soap dispensers activated by sensor; water and soap time adjustable; adjustable water temperature; chrome faucets
- additional accessories mounted to the wall available: water taps, soap and disinfectant dispensers, brush dispensers and paper towels dispensers
- available with ALVO CleanDrains siphon

	L	S	H	
2-093-1	845	635	1270	single bay
2-093-2	1600	635	1270	double bay
2-093-3	2355	635	1270	triple bay



2-094

Surgical sink, flush mounted into into wall panel system

- scrub sink intended for installation into wall panel systems, installed flush against surrounding walls/panels
- wall panel, counter-top and sink made of Corian
- built-in apron contour protects from splashing water
- infrared water tap, electric powered
- stainless steel siphon equipped as standard
- available with ALVO CleanDrains siphon

	L	S	H	
2-094-1	990	730	670	single bay
2-094-2	1740	730	670	double bay
2-094-3	2490	730	670	triple bay



2-095

Surgical sink

- wall-mounted scrub sink with wall panel
- wall panel made of stainless, acid-resistant 1.4301
- counter-top and sink made of Corian, built-in apron contour protects from splashing water
- infrared water tap, electric powered
- stainless steel siphon equipped as standard
- available with ALVO CleanDrains siphon

	L	S	H	
2-095-1	850	815	790	single bay
2-095-2	1600	815	790	double bay
2-095-3	2350	815	790	triple bay



02

SURGICAL SINKS



Human-oriented design

We take a human-oriented design approach when developing new medical products.

To truly understand what the top tasks of the surgical teams are when they enter the scrub rooms and how well these tasks can be performed, we use ethnographically informed research and co-design sessions. By moving design activity into the OR routine, our team has created a new modular scrub sink, calling it „a great piece of furniture which helps to prevent the spread of infection“.

The new ALVO scrub sink unit with superior design lines, enhanced functionality and easy to clean hygienic surfaces is the right solution for any operating theatre.

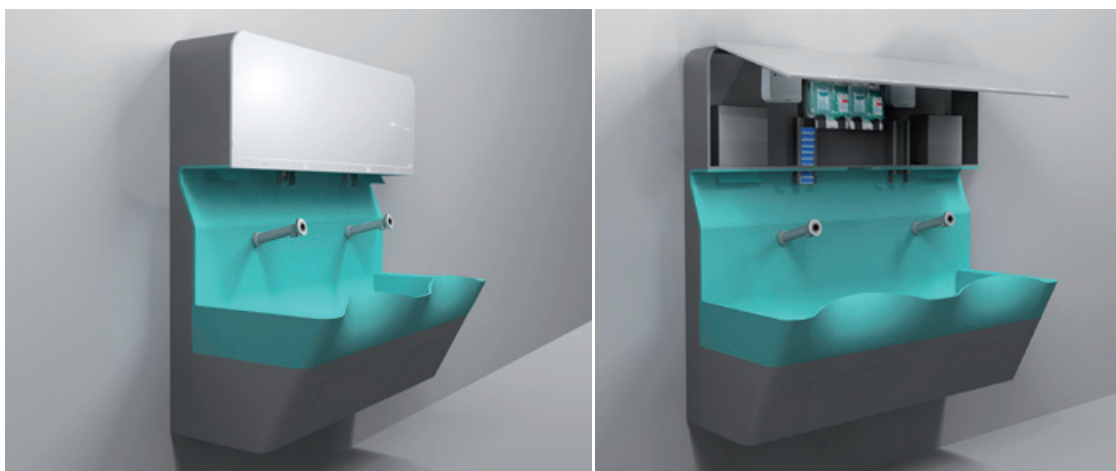

2-096 Surgical scrub sink unit

- wall mounted scrub sink unit with accessories
- paper towels, brushes, disinfectant and soap dispensers come flush behind the mirror or art panel, which makes additional storage space
- ergonomic apron contour protects from splashing the water
- rounded corners avoid collisions or snags on clothing
- infrared water faucets
- easy to clean materials with antimicrobial solutions
- available with ALVO CleanDrains siphon for drains disinfection



Three different colors available

*„A great piece of furniture which helps
to prevent the spread of infection“*

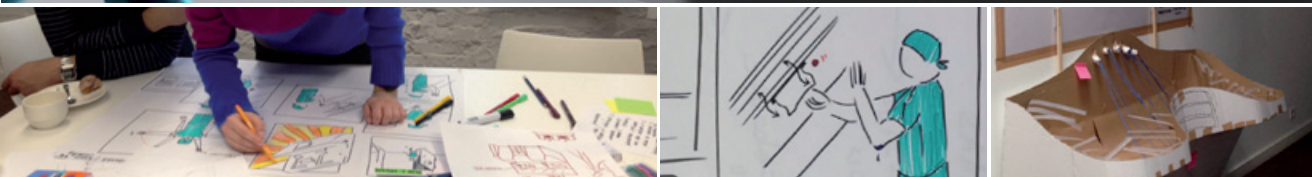
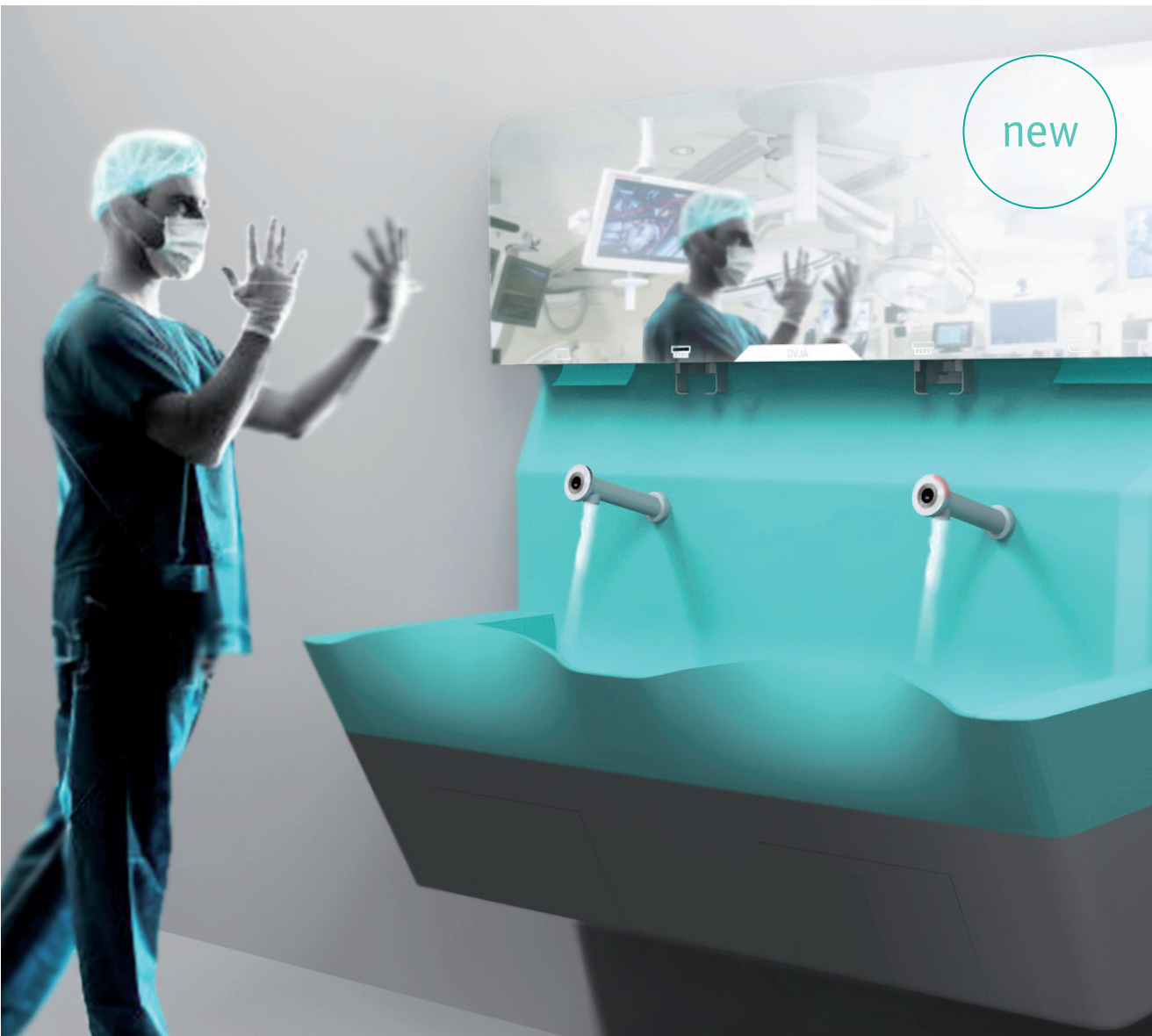

02

SURGICAL SINKS

2-900 Brush Dispenser

- made of stainless steel 1.4301
- includes 6 brushes

	L	S	H
2-900	130	83	341



2-901 | 2-902 Disinfectant fluid or soap dispenser

- dispenser made of stainless steel
- available touch free dispenser and elbow operated dispenser
- the dispenser is filled up by removing the container from the dispenser
- two sizes available: 500 ml and 1000 ml



2-903 | 2-904 Paper towels dispenser - 250 pcs, 500 pcs

- wall mounted paper towels dispenser, produced by Merida Sp. z o.o.
- the dispenser is filled up by opening upper cover

2-905 Elbow operated water tap, wall mounted

- elbow operated water tap with extended clinical handle
- specifically designed for models: 2-090, 2-091, 2-094, 2-095

2-906 Infrared water tap mounted to the sink

- infrared water tap, connected to the main power supply
- specifically designed for models: 2-091, 2-094, 2-095

2-907 Infrared water tap wall mounted

- infrared water tap, connected to a battery
- specifically designed for models: 2-090, 2-091, 2-094, 2-095

2-908 Infrared water tap with infrared fluid dispenser

- infrared water tap and fluid dispenser
- specifically designed for models: 2-091, 2-093, 2-094, 2-095

2-911 Mirror for scrub sinks mounted over the sink

- dimensions according to the requirement

2-912 Infrared water tap

- wall mounted infrared water tap
- specifically designed for the product number: 2-091, 2-094, 2-095

2-913 ALVO CleanDrains system

ALVO uses a CE-certified disinfection system for sink drains in clinical sanitary areas. Its continuous and fully automatic disinfection process prevents the production of infectious bio-aerosols and thus the transfer of pathogens from the wash basin to the patient.



03
INSTRUMENT TABLES



ALVO instrument and dressing tables are made of the highest quality of stainless steel and designed to support medical staff in all situations. The tables are created to store surgical instruments and dressings during and after the surgical intervention or examination procedure.

MAIN FEATURES:

The tables are equipped with high quality castors with non-smudging wheels and bumpers which protect the table from damage. The tables have ergonomic handles for easy maneuvering. Additional accessories such as drawers, bowls and trays can also be included.





2-001
Mayo table

- table made of stainless steel 1.4301
- height adjusted table top by hydraulic pump with foot lever, and with 360° horizontal rotation
- possibility of having flat or recessed table top
- table top dimensions: 740x490 mm
- t-shape base on three castors with diameter 80 mm, with brakes and non-smudging wheels
- permissible load: 15 kg

CE

	L	S	H
2-001	740	490	960/1370



2-010
Mayo table

- table made of stainless steel 1.4301
- manually height adjusted table top, and with 360° horizontal rotation
- possibility of having flat or recessed table top
- table top dimensions: 615x405 mm
- t-shape base on three castors with diameter 50 mm, with brakes and non-smudging wheels
- permissible load: 5 kg

CE

	L	S	H
2-010	640	450	920/1370



2-002
Surgical instrument table

- table made of stainless steel 1.4301
- manually height adjusted by crank handle
- possibility of having flat or recessed table top
- table top dimensions: 1200x600 mm
- based on four castors with diameter 80 mm with brakes and non-smudging wheels
- permissible load: 20 kg

	L	S	H
2-002	1270	600	1000/1400



2-016

Surgical instrument and medical staff table

- table made of stainless steel 1.4301
- one removable container on the table top, the container has cover with seal
- depth of the container: 470 mm
- dimensions of the table top: 536x336 mm
- possibility of having flat or recessed table top
- a fixed shelf with upraised edges, situated 150 mm above the floor
- distance between table top and shelf 640 mm
- handle situated along the shorter side of the table top
- container's dimensions:
exterior: 325x176x200 mm
interior: 300x150x200 mm
- based on four castors with diameter 80 mm, two of them with brakes
- castors with non-smudging wheels and plastic bumpers

	L	S	H
2-016	860	440	850



2-017

Surgical instrument and medical staff table

- table made of stainless steel 1.4301
- two removable containers on the table top, the bigger container has cover with seal
- depth of the containers: 470 mm
- a fixed shelf with upraised edges, situated 150 mm above the floor
- handle situated along the shorter side of the table top
- exterior containers' dimensions:
smaller: 530x325x200 mm
bigger: 325x176x200 mm
- interior containers' dimensions:
smaller: 500x300x200 mm
bigger: 300x150x200 mm
- based on four castors with diameter 80 mm, two of them with brakes
- castors with non-smudging wheels and plastic bumpers
- possibility of having flat or recessed table top

	L	S	H
2-017	860	440	850



2-201

Treatment trolley

- table made of stainless steel 1.4301 with flat or recessed table top
- possibility of having one or two drawers under the table top
- additionally, the table top can be design as removable tray, or as removable basket
- handle situated along the shorter side of the table top, option without handle also available, as instrument table
- based on four castors with diameter 100 mm, two of them with brakes
- castors with non-smudging wheels and plastic bumpers
- available a version for assembly, catalogue number: 2-211

CE

	L	S	H	table top
2-201-1	765	470	880	650x400
2-201-2	865	720	880	750x650
2-201-3	1115	720	880	1000x650
2-201-4	1315	720	880	1200x650
	L	S	H	table top
2-211-1	720	470	880	650x400
2-211-2	820	720	880	750x650
2-211-3	1070	720	880	1000x650
2-211-4	1270	720	880	1200x650



03

INSTRUMENT TABLES



2-202

Treatment trolley

- table made of stainless steel 1.4301, with flat or recessed table top and shelf
- possibility of having one or two drawers under the table top
- additionally, the table top and the shelf can be design as removable trays, or as removable baskets
- distance between the table top and shelf of 445 mm
- handle situated along the shorter side of the table top
- based on four castors with diameter 100 mm, two of them with brakes
- castors with non-smudging wheels and plastic bumpers
- available a version for assembly, catalogue number: 2-212



	L	S	H	table top
2-202-1	765	470	880	650x400
2-202-2	865	720	880	750x650
2-202-3	1115	720	880	1000x650
2-202-4	1615	720	880	1200x650

	L	S	H	table top
2-212-1	720	470	880	650x400
2-212-2	820	720	880	750x650
2-212-3	1070	720	880	1000x650
2-212-4	1270	720	880	1200x650

2-920 Drawer

- made of stainless steel 1.4301

2-934 | 2-936 Bowl with handle

- made of stainless steel 1.4301

2-941 Holder for plastic bags

- made of stainless steel 1.4301



04
ANESTHESIA
AND EMERGENCY
TROLLEYS



The anesthesia cabinets and trolleys are designed to keep the surgical instruments and supplies near at hand during surgical interventions and other procedures in the operating room.

MAIN FEATURES:

The cabinets can be tailor-made, adjusting to the customers' needs and requirements, with different combinations of drawers, cabinets and shelves. Drawers are installed on ball bearing rails which allow the drawer to be extended to 80% of its length, with a safety retaining system. The ergonomic fittings are made of stainless steel or antimicrobial copper upon request, and enable easy maneuvering. The trolleys are equipped with high quality castors with non-smudging wheels and bumpers which protect table from damage.



04

ANESTHESIA AND EMERGENCY TROLLEYS

ALVO[®]
MEDICAL



2-301
Anesthesia trolley

- trolley made of stainless steel 1.4301
- cabinet with double wing doors
- flat or recessed table top
- handle situated at front side of the trolley
- one fixed shelf made of stainless steel in the interior
- base on four castors with diameter 100 mm, two of them with brakes
- table top dimensions: 650 x 600 mm

	L	S	H
2-301	690	700	985



2-302
Anesthesia trolley

- trolley made of stainless steel 1.4301
- two drawers under the table top and cabinet with double wing doors
- flat or recessed table top
- handle situated at front side of the trolley
- one fixed shelf made of stainless steel in the interior
- base on four castors with diameter 100 mm, two of them with brakes
- table top dimensions: 650 x 600 mm

	L	S	H
2-302	690	700	985



2-303
Anesthesia trolley

- trolley made of stainless steel 1.4301
- three drawers and a fixed shelf under the table top
- flat or recessed table top
- the drawers, on ball bearing slides, have the same size
- handle situated at front side of the trolley
- base on four castors with diameter 100 mm, two of them with brakes
- table top dimensions: 650 x 600 mm

	L	S	H
2-303	690	700	985



2-305
Anesthesia trolley

- trolley made of stainless steel 1.4301
- two drawers and a fixed shelf under the table top
- flat or recessed table top
- the drawers, on ball bearing slides, have the same size
- handle situated at front side of the trolley
- base on four castors with diameter 100 mm, two of them with brakes
- table top dimensions: 650 x 600 mm

	L	S	H
2-305	690	700	985



2-316
Anesthesia trolley

- trolley made of stainless steel 1.4301
- one big drawer under the table top
- flat or recessed table top
- under the drawer: on left side, one wing door cabinet with one fixed shelf inside; on the right side, three drawers
- drawers on ball bearing slides
- handle situated at front side of the trolley
- base on four castors with diameter 100 mm, two of them with brakes
- table top dimensions: 650 x 600 mm

	L	S	H
2-316	690	700	985



2-317
Anesthesia trolley

- trolley made of stainless steel 1.4301
- eight drawers divided in two columns under the table top
- flat or recessed table top
- drawers on ball bearing slides
- handle situated at front side of the trolley
- base on four castors with diameter 100 mm, two of them with brakes
- table top dimensions: 650 x 600 mm

	L	S	H
2-317	690	700	985



04

ANESTHESIA AND EMERGENCY TROLLEYS

ALVO[®]
MEDICAL



2-318
Anesthesia trolley

- trolley made of stainless steel 1.4301
- four same size drawers under, on ball bearing slides
- flat or recessed table top
- handle situated at front side of the trolley
- base on four castors with diameter 100 mm, two of them with brakes
- table top dimensions: 650 x 600 mm

	L	S	H
2-318	690	700	985



2-319
Anesthesia trolley

- trolley made of stainless steel 1.4301
- three same size drawers under the table top and two smaller drawers below in a row
- drawers on ball bearing slides
- flat or recessed table top
- handle situated at front side of the trolley
- base on four castors with diameter 100 mm, two of them with brakes
- table top dimensions: 650 x 600 mm

	L	S	H
2-319	690	700	985



2-325
Anesthesia trolley

- trolley made of stainless steel 1.4301
- one drawer under the table top and six drawer divided in two columns below
- drawers on ball bearing slides
- flat or recessed table top
- handle situated at front side of the trolley
- base on four castors with diameter 100 mm, two of them with brakes
- table top dimensions: 650 x 600 mm

	L	S	H
2-325	690	700	985



2-340
Anesthesia trolley

- trolley made of stainless steel 1.4301
- two small drawers under a sliding table top, and two big drawers in the lower part of the trolley
- drawers on ball bearing slides
- flat or recessed table top
- distance between the two groups of drawers of 260 mm, serving as a shelf
- handle situated at front side of the trolley
- base on four castors with diameter 50 mm, two of them with brakes
- table top dimensions: 500 x 400 mm

	L	S	H
2-340	570	470	1100



2-345
Emergency trolley
with two drawers

- emergency trolley made of stainless steel 1.4301
- two same size drawers under the table top and a shelf under the drawers
- drawers on ball bearing slides
- table top with upraised back and sides edges
- handle situated at front side of the trolley
- base on four castors with diameter 100 mm, two of them with brakes
- castors with non-smudging wheels and plastic bumpers
- table top dimensions: 650 x 600 mm

	L	S	H
2-345	690	700	985



2-346
Emergency trolley
with four drawers

- emergency trolley made of stainless steel 1.4301
- four same size drawers under the table top
- drawers on ball bearing slides
- table top with upraised back and sides edges
- handle situated at front side of the trolley
- base on four castors with diameter 100 mm, two of them with brakes
- castors with non-smudging wheels and plastic bumpers
- table top dimensions: 650 x 600 mm

	L	S	H
2-346	690	700	985



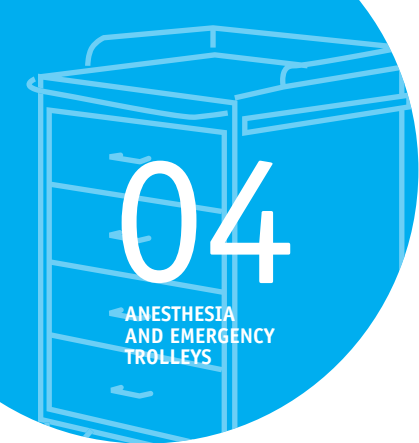

Accessories to anesthesia and emergency trolleys

2-933 Handles made of antimicrobial copper

- handles for doors or drawers
- color of stainless steel

2-934 Handles made of antimicrobial copper

- handles for doors or drawers.
- color of copper

2-935 Central lock

2-938 7l bucket with a handle

- made of stainless steel 1.4301

2-939 Wire waste basket with cover

- made of stainless steel 1.4301

2-940 Waste collector

- made of plastic
- knee operated

2-941 Holder for plastic bags

- made of stainless steel 1.4301

2-942 Infusion holder

- made of stainless steel 1.4301

2-943 Gloves container

- made of stainless steel 1.4301 rods

2-944 Gloves container

- made of stainless steel 1.4301

2-945 Tray with handle

- made of stainless steel 1.4301

2-946 Disposable box for needles

- made of plastic

2-947 Disposable box for needles

- made of stainless steel 1.4301

2-949 Retractable work surface

- located in the side of the trolley
- made of stainless steel 1.4301

2-950 Catheter quiver

- made of stainless steel 1.4301

2-951 Stand for syringe and needle plastic dispenser

- stand made of stainless steel 1.4301, containers made of plastic
- 11 containers

2-952 Shelf over the table top

- made of stainless steel 1.4301



04

ANESTHESIA
AND EMERGENCY
TROLLEYS





05
EQUIPMENT
FOR OPERATING
ROOMS



ALVO equipment for operating rooms is made of the highest quality materials. This group includes buckets, bowl holders, medical stools, medical steps and drip bottle holders. The equipment is designed to support the medical staff in the OR and are designed to complement all products from the ALVO catalogue.

MAIN FEATURES:

The products of this group are made of high quality stainless steel. The products are equipped with high quality castors with non-smudging wheels. All upholstery is made of high quality materials, which are resistant to disinfectants used in the OR.



05

EQUIPMENT
FOR OPERATING
ROOMS

ALVO[®]
MEDICAL



2-020

IV-Pole

- made of stainless steel 1.4301
- height adjusted by hand: 1200-2150 mm
- three arm base with castors, all of them with brake
- diameter of the castors: 50 mm
- permissible load: 8 kg

OPTIONS:

- 2-020-0: stand with four hooks, without tray
- 2-020-1: stand with two hooks, without tray
- 2-020-2: stand with two bottle holders, without tray
- 2-020-3: stand with two bottle holders and tray



	L	S	H	
2-020-0	560	560	1200/2150	4 hooks
2-020-1	560	560	1200/2150	2 hooks
2-020-2	560	560	1200/2150	2 bottle holders
2-020-3	560	560	1200/2150	2 bottle holders



2-031-1

Bowl holder

- made of stainless steel 1.4301
- bowl stand on five arm base with five castors diameter 50 mm, two of them with brakes
- one removable bowl 3 or 6 l
- permissible load of bowl stand 2-031: 6 kg



	L	S	H	
2-031-1	560	560	850	3 l bowl
2-031-2	600	560	850	6 l bowl



2-032-1

Bowl holder

- made of stainless steel 1.4301
- bowl stand on five arm base with five castors diameter 50 mm, two of them with brakes
- two removable bowls 3 or 6 l
- permissible load: 12 kg

CE

	L	S	H	
2-032-1	560	580	850	3 l bowl
2-032-2	560	700	850	6 l bowl



2-033-1

Heated bowl holder with height adjustment

- made of stainless steel 1.4301
- bowl stand on five arm base with five castors diameter 50 mm, all of them with brakes
- height adjusted from 1140 to 1280 mm by hydraulic pump with foot lever
- power – 230V/600W
- cable length 3 meters
- one stainless steel bowl with capacity of 6 l
- termoregulated heated plate, adjustment by knob, max temperature of heated fluid 70°C

CE

	L	S	H
2-033-1	560	560	1140/1280



2-033-2

Heated bowl holder with height adjustment

- made of stainless steel 1.4301
- bowl stand on five arm base with five castors diameter 50 mm, all of them with brakes
- height adjusted from 1140 to 1280 mm by hydraulic pump with foot lever
- power – 230V/600W
- cable length 3 meters
- one stainless steel bowl with capacity of 6 l
- microprocessor thermostat, electronically adjusted heat; max temperature of heated fluid 85°C

CE

	L	S	H
2-033-2	560	560	1140/1280





2-033-3
Heated bowl holder

- made of stainless steel 1.4301
- bowl stand on five arm base with five castors diameter 50 mm, all of them with brakes
- power – 230V/600W
- cable lenght 3 meters
- two stainless steel bowls with capacity of 6 l
- termoregulated heated plate, adjustment by knob, max temperature of heated fluid 70°C

CE

	L	S	H
2-033-3	560	560	1100



2-033-4
Heated bowl holder

- made of stainless steel 1.4301
- bowl stand on five arm base with five castors diameter 50 mm, all of them with brakes
- power – 230V/600W
- cable lenght 3 meters
- two stainless steel bowls with capacity of 6 l
- microprocessor termostate, electronically adjusted heat; max temperature of heated fluid 85°C

CE

	L	S	H
2-033-4	560	560	1100



2-035
Bucket mobile

- made of stainless steel 1.4301
- removable bucket on five arm base with five castors diameter 50 mm, without brakes
- bucket capacity – 10 l
- with 750 mm long handle

	L	S	H
2-035	360	360	760



2-036

Bucket mobile

- made of stainless steel 1.4301
- removable bucket on five arm base with five castors diameter 50 mm, without brakes
- bucket capacity – 10 l

	L	S	H
2-036	360	360	400



2-040

Medical stool with manual height adjustment

- made of stainless steel 1.4301
- round metal seat
- diameter of the seat: 360 mm
- gas spring supported height adjustment by hand lever
- three arm base with castors diameter 50 mm, two of them with brakes
- permissible load: 135 kg

CE

	L	S	H
2-040	480	480	460/600



2-041

Medical stool with hydraulic height adjustment

- made of stainless steel 1.4301
- round metal seat
- diameter of the seat: 360 mm
- hydraulic height adjustment by foot lever
- three arm base with castors diameter 50 mm, two of them with brakes
- permissible load: 135 kg

CE

	L	S	H
2-041	480	480	460/600



05

EQUIPMENT
FOR OPERATING
ROOMS

ALVO[®]
MEDICAL



2-042

Medical stool with manual height adjustment

- made of stainless steel 1.4301
- round seat covered of high quality upholstery fabric (available colors in page 102). Under request, the seat can be covered of polyurethane.
- diameter of the seat: 350 mm
- gas spring supported height adjustment by hand lever
- three arm base with castors diameter 50 mm, two of them with brakes
- permissible load: 135 kg

CE

	L	S	H
2-042	480	480	490/630



2-043

Medical stool with manual height adjustment

- made of stainless steel 1.4301
- round seat covered of high quality upholstery fabric (available colors in page 102). Under request, the seat can be covered of polyurethane.
- diameter of the seat: 350 mm
- ergonomic, height adjusted back rest
- pneumatic height adjustment by hand lever
- three arm base with castors diameter 50 mm, two of them with brakes
- permissible load: 135 kg

CE

	L	S	H
2-043	480	480	490/630



2-044

Medical stool with backrest

- made of stainless steel 1.4301
- round seat covered of high quality upholstery fabric (available colors in page 102). Under request, the seat can be covered of polyurethane.
- diameter of the seat: 360 mm
- ergonomic, height adjusted back rest
- hydraulic height adjustment by foot lever
- three arm base with castors diameter 50 mm, two of them with brakes
- permissible load: 135 kg

CE

	L	S	H
2-044	480	480	490/630



2-045

Medical stool with hydraulic height adjustment

- made of stainless steel 1.4301
- round seat covered of high quality upholstery fabric (available colors in page 102). Under request, the seat can be covered of polyurethane.
- diameter of the seat: 350 mm
- hydraulic height adjustment by foot lever
- three arm base with castors diameter 50 mm, two of them with brakes
- permissible load: 135 kg

CE

	L	S	H
2-045	480	480	490/630



2-046

Medical stool with ergonomic seat

- made of stainless steel 1.4301
- ergonomic seat covered of high quality upholstery fabric (available colors in page 102). Under request, the seat can be covered of polyurethane.
- diameter of the seat: 360 mm
- hydraulic height adjustment by foot lever
- three arm base with castors diameter 50 mm, two of them with brakes
- permissible load: 135 kg

CE

	L	S	H
2-046	480	480	460/600

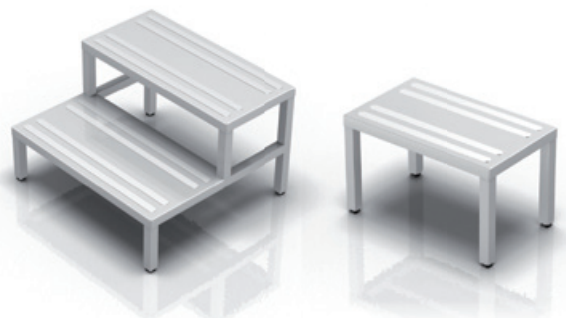

2-050 | 2-051

Surgical platform

- four small legs with level adjustment possibility
- steps with anti slippery stripes

	L	S	H	
2-050	500	650	410	2 steps
2-051-1	500	300	120	1 step
2-051-2	500	300	250	1 step
2-051-3	500	300	300	1 step



05
EQUIPMENT
FOR OPERATING
ROOMS





06

TROLLEYS
FOR MEDICAL
DEVICES



ALVO trolleys for medical devices are made of the highest quality stainless steel. During the design process, the trolleys with fixed shelves can be adapted to the customers' devices. Some of the trolleys have adaptable shelves as a standardized feature.

MAIN FEATURES:

Drawers are installed on ball bearing rails, which enable them to slide to 80% of their length, with a safety retaining system. The trolleys are equipped with high quality castors with non-smudging wheels.



06

TROLLEYS
FOR MEDICAL
DEVICES

ALVO®
MEDICAL



2-550
Trolley for medical devices

- made of stainless steel 1.4301
- two fixed shelves and one drawer in lower part of trolley
- distance between shelves: 400 mm
- distance between shelf and drawer: 180 mm
- height of the drawer:
 - exterior: 150 mm
 - interior: 110 mm
- castors with diameter 100 mm, two of them with brakes

	L	S	H
2-550	650	550	1300



2-551
Trolley for medical devices

- made of stainless steel 1.4301
- three fixed shelves and one drawer in lower part of trolley
- distance between shelf and drawer: 180 mm
- distances between shelves: 180 mm
- height of the drawer:
 - exterior: 150 mm
 - interior: 110 mm
- castors with diameter 100 mm, two of them with brake

	L	S	H
2-551	650	550	1300



2-552
Trolley for medical devices

- made of stainless steel 1.4301
- four fixed shelves and one drawer in lower part of trolley
- distances between shelves: 180 mm
- height of the drawer:
 - exterior: 150 mm
 - interior: 110 mm
- castors with diameter 100 mm, two of them with brakes

	L	S	H
2-552	650	550	1300



2-560
Trolley for medical devices

- made of stainless steel 1.4301
- two adjustable shelves and one drawer in lower part of trolley
- height of the drawer:
 - exterior: 150 mm
 - interior: 110 mm
- two maneuvering handles
- trolley with six electric sockets
- castors with diameter 100 mm, two of them with brakes

	L	S	H
2-560	650	700	1470

885
including
the oxygen
bottle holder



2-561
Trolley for medical devices

- made of stainless steel 1.4301
- three adjustable shelves and one drawer in lower part of trolley
- height of the drawer:
 - exterior: 150 mm
 - interior: 110 mm
- two maneuvering handles
- trolley with six electric sockets
- castors with diameter 100 mm, two of them with brakes

	L	S	H
2-561	650	700	1470

885
including
the oxygen
bottle holder



2-562
Trolley for medical devices

- made of stainless steel 1.4301
- trolley with four adjustable shelves and one drawer in lower part of trolley
- height of the drawer:
 - exterior: 150 mm
 - interior: 110 mm
- two maneuvering handles
- trolley with oxygen bottle holder, six electric sockets and camera holder
- castors with diameter 100 mm, two of them with brake

	L	S	H
2-562	650	700	1470

885
including
the oxygen
bottle holder



06

TROLLEYS FOR MEDICAL DEVICES

ALVO[®]
MEDICAL



2-570
Trolley for medical devices

- made of stainless steel 1.4301
- trolley with one drawer in upper part and two shelves, fixed
- distance between shelves 240 mm
- flat table top and shelves
- maneuvering handle
- oxygen bottle holders
- castors with diameter 100 mm, two of them with brakes

	L	S	H
2-570	440	700	860



2-571
Trolley for medical devices

- made of stainless steel 1.4301
- trolley with one drawer in the middle, and two shelves
- distance between shelves 240 mm
- flat table top and shelves
- maneuvering handle
- oxygen bottle holders
- castors with diameter 100 mm, two of them with brakes

	L	S	H
2-571	440	700	860



2-985
Oxygen bottle holder

- shelf for bottles, made of stainless steel 1.4301
- safety strap, made of high quality material



07

TROLLEYS
FOR LINEN
TRANSPORTATION



ALVO trolleys for linen transportation are made of the highest quality stainless steel. The trolleys are designed to store clean and dirty linen in the operating room and other facilities.

MAIN FEATURES:

As standard catalogue products we offer single, double and triple trolleys in multiple sizes. The bag holder is designed to hold every kind and size of bag. Trolleys can be made with cover or without cover. The covers can be ordered in colors, and can be opened manually or by foot lever. Trolleys are equipped with high quality castors with non-smudging wheels.



07

TROLLEYS
FOR LINEN
TRANSPORTATION

ALVO[®]
MEDICAL



2-100 | 2-101
Trolley for plastic bags

- single trolley made of stainless steel 1.4301
- special clips for plastic bags
- castors with diameter 50 mm, two castors with brakes
- cover made of stainless steel with matte finish. Under request, possibility to have bright finish stainless steel cover or plastic cover with three different colors available

Without cover:

	L	S	H	
2-100-1	340	380	560	30 l
2-100-2	400	440	710	60 l
2-100-3	400	450	910	100 l
2-100-4	400	450	1050	120 l

With cover:

	L	S	H	
2-101-1	340	460	560	30 l
2-101-2	400	510	710	60 l
2-101-3	415	510	910	100 l
2-101-4	415	580	1050	120 l



2-102 | 2-103
Trolley for plastic bags

- double trolley made of stainless steel 1.4301
- special clips for plastic bags
- castors with diameter 50 mm, two castors with brakes
- covers made of stainless steel with matte finish. Under request, possibility to have bright finish stainless steel covers or plastic covers with three different colors available

Without cover:

	L	S	H	
2-102-1	840	440	710	60 l
2-102-2	840	450	910	100 l
2-102-3	840	450	1050	120 l

With cover:

	L	S	H	
2-103-1	840	510	710	60 l
2-103-2	860	510	910	100 l
2-103-3	860	580	1050	120 l



2-104 | 2-105
Trolley for plastic bags

- made of stainless steel 1.4301
- special clips for plastic bags
- castors with diameter 50 mm, two castors with brakes
- covers made of stainless steel with matte finish. Under request, possibility to have bright finish stainless steel covers or plastic covers with three different colors available

Without cover:

	L	S	H	
2-104-1	1280	440	710	60 l
2-104-2	1280	450	910	100 l
2-104-3	1280	450	1050	120 l

With cover:

	L	S	H	
2-105-1	1280	510	710	60 l
2-105-2	1300	510	910	100 l
2-105-3	1300	580	1050	120 l



2-110

Trolley for clean and dirty linen

- trolley with two shelves, without doors, made of stainless steel 1.4301
- table top with protecting rails 600x600 mm
- on back side of the trolley holder for bag 120 l, without cover
- castors with diameter 100 mm, two of them with brakes
- non-smudging wheels with bumpers

	L	S	H
2-110	640	1160	1100



2-111

Trolley for clean and dirty linen

- trolley with two shelves and single door, made of stainless steel 1.4301
- table top with protecting rails 600x600 mm
- on back side of the trolley holder for bag 120 l, with cover open by foot lever
- castors with diameter 100 mm, two of them with brakes
- non-smudging wheels with bumpers

	L	S	H
2-111	640	1190	1100



2-112

Refuse bag trolley

- trolley made of stainless steel 1.4301
- free-opening cover, stops upon opening
- side flap opens to cart height, upper flap opens to flat height
- four castors with diameter 160 mm, two of them with brake
- non-smudging wheels with bumpers
- safe, rounded edges

	L	S	H
2-112-1	1110	660	1100
2-112-2	1310	660	1100



07

TROLLEYS
FOR LINEN
TRANSPORTATION





08

MEDICAL
AND STORAGE
CABINETS

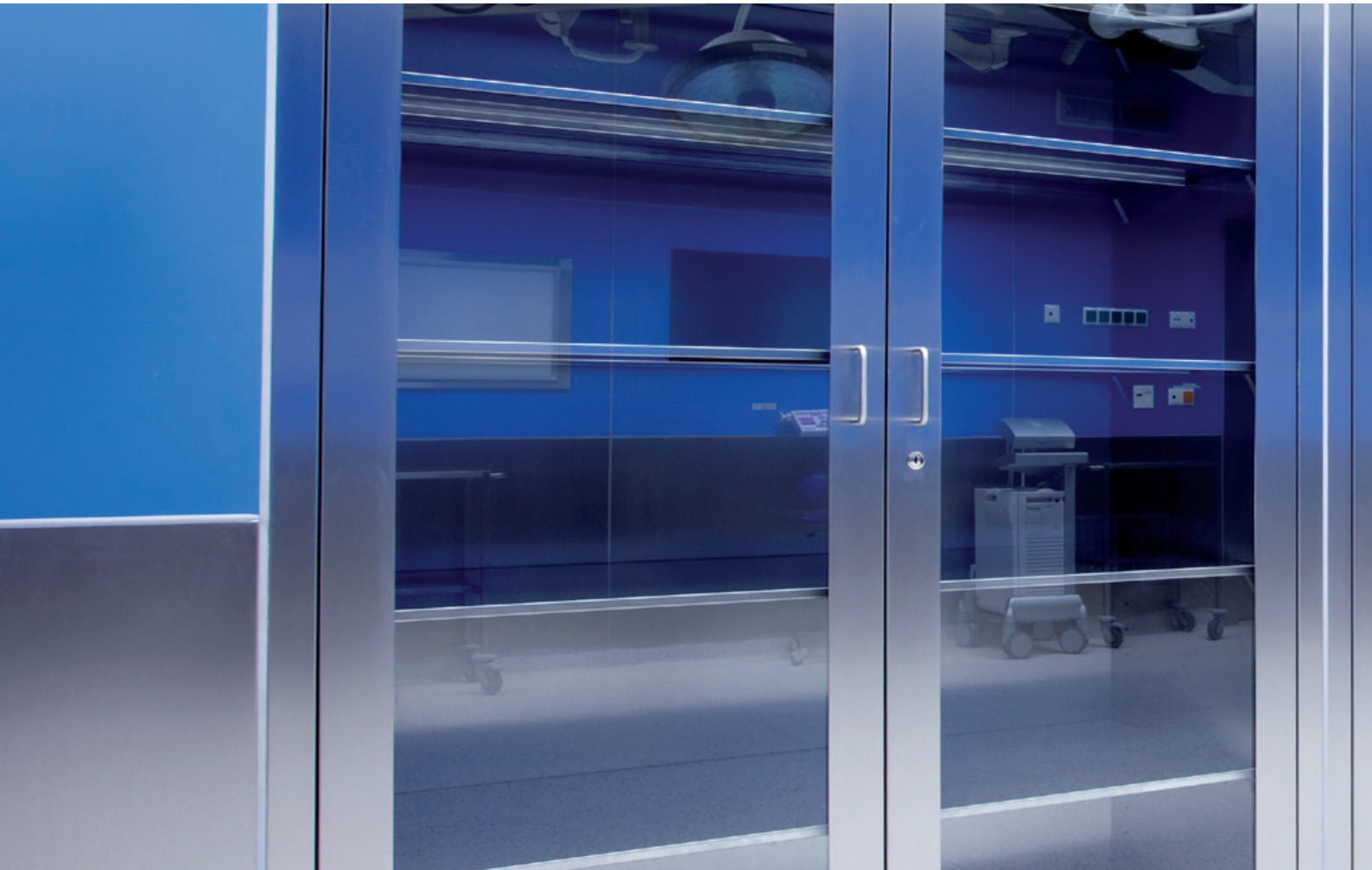

ALVO cabinets are made of the highest stainless steel panels and fit perfectly with the ALVO modular OR system. The cabinets can be adapted to the customers' needs in different configurations.

MAIN FEATURES:

As standard products we offer cabinets made of stainless steel or stainless steel with glass. The cabinets can be self-standing, wall hanging or built-in the modular wall system. The doors can be right or left-opening. Doors and sides can be fitted with safety glass. Shelves are made of stainless steel and can be adjusted. As an additional feature the doors can have locks.



08

MEDICAL AND STORAGE CABINETS

ALVO[®]
MEDICAL



2-250
Medical cabinet

- made of stainless steel 1.4301
- one wing door, with lock and handle
- five adjustable shelves made of stainless steel
- cabinet with skirting board or on 140 mm legs with leveling adjustment

	L	S	H
2-250-1	400	470	1800
2-250-2	500	470	1800
2-250-3	600	470	1800
2-250-4	400	580	2000
2-250-5	500	580	2000
2-250-6	600	580	2000



2-251
Medical cabinet

- made of stainless steel 1.4301 and safety glass
- one glass wing door, with lock and handle
- five adjustable shelves made of stainless steel
- cabinet with skirting board or on 140 mm legs with leveling adjustment

	L	S	H
2-251-1	400	470	1800
2-251-2	400	470	1800
2-251-3	400	470	1800
2-251-4	400	580	2000
2-251-5	500	580	2000
2-251-6	600	580	2000



2-252
Medical cabinet

- made of stainless steel 1.4301 and safety glass
- one glass wing door and glass sides
- door with lock and handle
- five adjustable shelves made of stainless steel
- cabinet with skirting board or on 140 mm legs with leveling adjustment

	L	S	H
2-252-1	400	470	1800
2-252-2	400	470	1800
2-252-3	400	470	1800
2-252-4	400	580	2000
2-252-5	500	580	2000
2-252-6	600	580	2000



2-253
Medical cabinet

- made of stainless steel 1.4301
- divided in two heights, both parts with full wing doors
- doors with lock and handle
- upper part with four adjustable stainless steel shelves
- lower part with one fixed stainless steel shelf
- cabinet with skirting board or on 140 mm legs with leveling adjustment

	L	S	H
2-253-1	400	470	1800
2-253-2	400	470	1800
2-253-3	400	470	1800
2-253-4	400	580	2000
2-253-5	500	580	2000
2-253-6	600	580	2000



2-254
Medical cabinet

- made of stainless steel 1.4301 and safety glass
- divided in two heights, upper part with glass wing door and lower part with full wing door
- doors with lock and handle
- upper part with four adjustable stainless steel shelves
- lower part with one fixed stainless steel shelf
- cabinet with skirting board or on 140 mm legs with leveling adjustment

	L	S	H
2-254-1	400	470	1800
2-254-2	400	470	1800
2-254-3	400	470	1800
2-254-4	400	580	2000
2-254-5	500	580	2000
2-254-6	600	580	2000



2-255
Medical cabinet

- made of stainless steel 1.4301 and safety glass
- divided in two heights, upper part with glass wing door and glass sides, and lower part with full wing door
- doors with lock and handle
- upper part with four adjustable stainless steel shelves
- lower part with one fixed stainless steel shelf
- cabinet with skirting board or on 140 mm legs with leveling adjustment

	L	S	H
2-255-1	400	470	1800
2-255-2	400	470	1800
2-255-3	400	470	1800
2-255-4	400	580	2000
2-255-5	500	580	2000
2-255-6	600	580	2000



08

MEDICAL
AND STORAGE
CABINETS

ALVO®
MEDICAL



2-260
Medical cabinet

- made of stainless steel 1.4301
- two wing doors, with lock and handle
- five adjustable shelves made of stainless steel
- cabinet with skirting board or on 140 mm legs with leveling adjustment

	L	S	H
2-260-1	800	470	1800
2-260-2	1000	470	1800
2-260-3	1200	470	1800
2-260-4	800	580	2000
2-260-5	1000	580	2000
2-260-6	1200	580	2000



2-265
Medical cabinet

- made of stainless steel 1.4301 and safety glass
- cabinet with two wing glass doors, with lock and handle
- five adjustable stainless steel shelves
- cabinet with skirting board or on 140 mm legs with leveling adjustment

	L	S	H
2-265-1	800	470	1800
2-265-2	1000	470	1800
2-265-3	1200	470	1800
2-265-4	800	580	2000
2-265-5	1000	580	2000
2-265-6	1200	580	2000



2-267
Medical cabinet

- made of stainless steel 1.4301 and safety glass
- cabinet with two wing glass doors and glass sides
- doors with lock and handle
- five adjustable stainless steel shelves
- cabinet with skirting board or on 140 mm legs with leveling adjustment

	L	S	H
2-267-1	800	470	1800
2-267-2	1000	470	1800
2-267-3	1200	470	1800
2-267-4	800	580	2000
2-267-5	1000	580	2000
2-267-6	1200	580	2000



2-261
Medical cabinet

- made of stainless steel 1.4301
- divided in two heights, both parts with two full wing doors
- upper part with four adjustable stainless steel shelves
- lower part with one fixed stainless steel shelf
- cabinet with skirting board or on 140 mm legs with leveling adjustment

	L	S	H
2-261-1	800	470	1800
2-261-2	1000	470	1800
2-261-3	1200	470	1800
2-261-4	800	580	2000
2-261-5	1000	580	2000
2-261-6	1200	580	2000



2-269
Medical cabinet

- made of stainless steel 1.4301 and safety glass
- divided in two heights, upper part with glass wing door and lower part with full wing door
- upper part with four adjustable stainless steel shelves
- lower part with one fixed stainless steel shelf
- cabinet with skirting board or on 140 mm legs with leveling adjustment

	L	S	H
2-269-1	800	470	1800
2-269-2	1000	470	1800
2-269-3	1200	470	1800
2-269-4	800	580	2000
2-269-5	1000	580	2000
2-269-6	1200	580	2000



2-270
Medical cabinet

- made of stainless steel 1.4301 and safety glass
- divided in two heights, upper part with glass wing door and glass sides, and lower part with full wing door
- upper part with four adjustable stainless steel shelves
- lower part with one fixed stainless steel shelf
- cabinet with skirting board or on 140 mm legs with leveling adjustment

	L	S	H
2-270-1	800	470	1800
2-270-2	1000	470	1800
2-270-3	1200	470	1800
2-270-4	800	580	2000
2-270-5	1000	580	2000
2-270-6	1200	580	2000



08

MEDICAL
AND STORAGE
CABINETS

ALVO[®]
MEDICAL



2-262
Medical cabinet

- made of stainless steel 1.4301
- two full sliding doors, with lock and handle
- five adjustable stainless steel shelves
- cabinet with skirting board or on 140 mm legs with leveling adjustment

	L	S	H
2-262-1	800	450	1800
2-262-2	1000	450	1800
2-262-3	1200	450	1800
2-262-4	800	580	2000
2-262-5	1000	580	2000
2-262-6	1200	580	2000



2-266
Medical cabinet

- made of stainless steel 1.4301 and safety glass
- two glass sliding doors, with lock and handle
- five adjustable stainless steel shelves
- cabinet with skirting board or on 140 mm legs with leveling adjustment

	L	S	H
2-266-1	800	450	1800
2-266-2	1000	450	1800
2-266-3	1200	450	1800
2-266-4	800	580	2000
2-266-5	1000	580	2000
2-266-6	1200	580	2000



2-268
Medical cabinet

- made of stainless steel 1.4301 and safety glass
- two glass sliding doors and glass sides
- doors with lock and handle
- five adjustable stainless steel shelves
- cabinet with skirting board or on 140 mm legs with leveling adjustment

	L	S	H
2-268-1	800	450	1800
2-268-2	1000	450	1800
2-268-3	1200	450	1800
2-268-4	800	580	2000
2-268-5	1000	580	2000
2-268-6	1200	580	2000



2-263

Medical cabinet

- made of stainless steel 1.4301
- divided in two heights, both parts with two full sliding doors
- doors with lock and handle
- upper part with four adjustable stainless steel shelves
- lower part with one fixed stainless steel shelf
- cabinet with skirting board or on 140 mm legs with leveling adjustment

	L	S	H
2-263-1	800	450	1800
2-263-2	1000	450	1800
2-263-3	1200	450	1800
2-263-4	800	580	2000
2-263-5	1000	580	2000
2-263-6	1200	580	2000

2-271

Medical cabinet

- made of stainless steel 1.4301 and safety glass
- divided in two heights, upper part with two glass sliding doors and lower part with two full sliding doors
- doors with lock and handle
- upper part with four adjustable stainless steel shelves
- lower part with one fixed stainless steel shelf
- cabinet with skirting board or on 140 mm legs with leveling adjustment

	L	S	H
2-271-1	800	450	1800
2-271-2	1000	450	1800
2-271-3	1200	450	1800
2-271-4	800	580	2000
2-271-5	1000	580	2000
2-271-6	1200	580	2000

2-272

Medical cabinet

- made of stainless steel 1.4301 and safety glass
- divided in two heights, upper part with two glass sliding doors and glass sides, and lower part with two full sliding doors
- doors with lock and handle
- upper part with four adjustable stainless steel shelves
- lower part with one fixed stainless steel shelf
- cabinet with skirting board or on 140 mm legs with leveling adjustment

	L	S	H
2-272-1	400	450	1800
2-272-2	500	450	1800
2-272-3	600	450	1800
2-272-4	400	580	2000
2-272-5	500	580	2000
2-272-6	600	580	2000

2-264

Two-sides opened medical cabinet

- made of stainless steel 1.4301, openable from front and back part
- divided in two heights, both parts with two full sliding doors
- doors with lock and handle
- upper part with four adjustable stainless steel shelves
- lower part with one fixed stainless steel shelf
- cabinet with skirting board or on 140 mm legs with leveling adjustment

	L	S	H
2-264-1	800	450	1800
2-264-2	1000	450	1800
2-264-3	1200	450	1800
2-264-4	800	580	2000
2-264-5	1000	580	2000
2-264-6	1200	580	2000



08

MEDICAL
AND STORAGE
CABINETS

ALVO®
MEDICAL



2-273

Medical wardrobe

- made of stainless steel 1.4301
- double wardrobe made of stainless steel with bench
- wing doors with lock and holes for ventilation
- one shelf and pole in each part
- cabinet on 140 mm legs with leveling adjustment

	L	S	H
2-273	650	750	2100

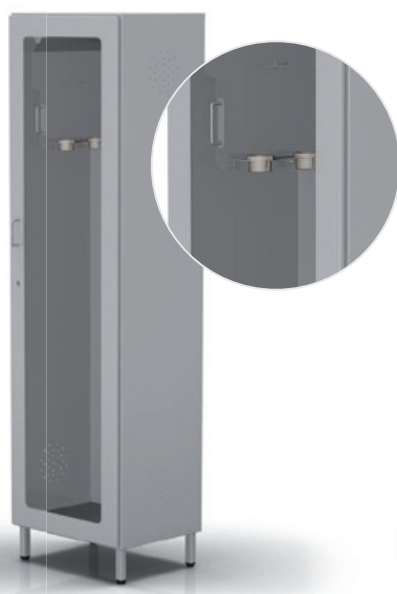

2-274

Endoscope storage cabinet

- made of stainless steel 1.4301 and safety glass
- one glass wing door, equipped with rubber insulation and handle
- perforated cabinet walls allow ventilation
- cabinet bottom comes equipped with a drip tray
- interior contains retractable hangers for storing endoscopes
- hangers are mounted on fully retractable ball rails
- each hanger is equipped with silicone inserts to protect instruments from damage
- cabinet with skirting board or on 140 mm legs with leveling adjustment

	L	S	H	
2-274-1	400	470	2150	1 endoscope
2-274-2	600	470	2150	2 endoscopes



2-275

Endoscope storage cabinet

- made of stainless steel 1.4301 and safety glass
- two glass wing doors, equipped with rubber insulation and handle
- perforated cabinet walls allow ventilation
- cabinet bottom comes equipped with a drip tray
- interior contains retractable hangers for storing endoscopes
- hangers are mounted on fully retractable ball rails
- each hanger is equipped with silicone inserts to protect instruments from damage
- cabinet with skirting board or on 140 mm legs with leveling adjustment

	L	S	H	
2-275-1	800	470	2150	4 endoscopes
2-275-2	1000	470	2150	5 endoscopes
2-275-3	1200	470	2150	6 endoscopes



2-276

Medical cabinet with electronic locking mechanism

- made of stainless steel 1.4301 and safety glass
- two glass wing doors with rubber insulation and handles
- doors equipped with locking mechanism - opening the door from one side disables opening from the other side
- locking mechanism signals opening/closing via green/red LED lighting which change color upon opening/closing
- five adjustable stainless steel shelves, totaling six surfaces

	L	S	H
2-276-1	400	450	1800
2-276-2	500	450	1800
2-276-3	600	450	1800
2-276-4	400	580	1800
2-276-5	500	580	1800
2-276-6	600	580	1800

2-277

Medical cabinet with electronic locking mechanism

- made of stainless steel 1.4301 and safety glass
- two double glass wing doors with rubber insulation and handles
- doors equipped with locking mechanism - opening the door from one side disables opening from the other side
- locking mechanism signals opening/closing via green/red LED lighting which change color upon opening/closing
- five adjustable stainless steel shelves, totaling six surfaces

	L	S	H
2-277-1	800	450	1800
2-277-2	1000	450	1800
2-277-3	1200	450	1800
2-277-4	800	580	1800
2-277-5	1000	580	1800
2-277-6	1200	580	1800

2-278

Catheter cabinet

- made of stainless steel 1.4301 and safety glass
- two glass wing doors, equipped with rubber insulation and handle
- perforated cabinet walls allow ventilation
- cabinet bottom comes equipped with a drip tray
- interior contains retractable hangers for storing catheters
- hangers are mounted on fully retractable ball rails
- each hanger is equipped with silicone inserts to protect instruments from damage
- cabinet with skirting board or on 140 mm legs with leveling adjustment

	L	S	H	
2-278-1	800	470	1800	5 retractable handles
2-278-2	1000	470	1800	6 retractable handles
2-278-3	1200	470	1800	7 retractable handles

* Under request, the height can change in order to adapt to the catheter's length.



08

MEDICAL
AND STORAGE
CABINETS

ALVO[®]
MEDICAL



2-280

Wall-mounted
medical cabinet

- wall-mounted cabinet without door made of stainless steel 1.4301
- one fixed stainless steel shelf, totaling two surfaces



2-281

Wall-mounted
medical cabinet

- wall-mounted cabinet made of stainless steel 1.4301
- full wing door
- one fixed stainless steel shelf, totaling two surfaces



2-282

Wall-mounted
medical cabinet

- wall-mounted cabinet made of stainless steel 1.4301 and safety glass
- glass wing door
- one fixed stainless steel shelf, totaling two surfaces



2-283

Wall-mounted
medical cabinet

- wall-mounted cabinet made of stainless steel 1.4301 and safety glass
- glass wing door and glass sides
- one fixed stainless steel shelf, totaling two surfaces

	L	S	H
2-280-1	400	350	600
2-280-2	500	350	600
2-280-3	600	350	600
2-280-4	800	350	600
2-280-5	1000	350	600
2-280-6	1200	350	600

	L	S	H
2-281-1	400	370	600
2-281-2	500	370	600
2-281-3	600	370	600

	L	S	H
2-282-1	400	370	600
2-282-2	500	370	600
2-282-3	600	370	600

	L	S	H
2-283-1	400	370	600
2-283-2	500	370	600
2-283-3	600	370	600



2-284
Wall-mounted
medical cabinet

- wall-mounted cabinet made of stainless steel 1.4301
- two full wing doors
- one fixed stainless steel shelf, totaling two surfaces

	L	S	H
2-284-1	800	370	600
2-284-2	1000	370	600
2-284-3	1200	370	600



2-285
Wall-mounted
medical cabinet

- wall-mounted cabinet made of stainless steel 1.4301 and safety glass
- two glass wing doors
- one fixed stainless steel shelf, totaling two surfaces

	L	S	H
2-285-1	800	370	600
2-285-2	1000	370	600
2-285-3	1200	370	600



2-286
Wall-mounted
medical cabinet

- wall-mounted cabinet made of stainless steel 1.4301 and safety glass
- two glass wing doors and glass sides
- one fixed stainless steel shelf, totaling two surfaces

	L	S	H
2-286-1	800	370	600
2-286-2	1000	370	600
2-286-3	1200	370	600



08

MEDICAL
AND STORAGE
CABINETS

ALVO[®]
MEDICAL



2-287

Wall-mounted medical cabinet

- wall-mounted cabinet made of stainless steel 1.4301
- two full sliding doors
- one fixed stainless steel shelf, totaling two surfaces

	L	S	H
2-287-1	800	350	600
2-287-2	1000	350	600
2-287-3	1200	350	600



2-288

Wall-mounted medical cabinet

- wall-mounted cabinet made of stainless steel 1.4301 and safety glass
- two glass sliding doors
- one fixed stainless steel shelf, totaling two surfaces

	L	S	H
2-288-1	800	350	600
2-288-2	1000	350	600
2-288-3	1200	350	600

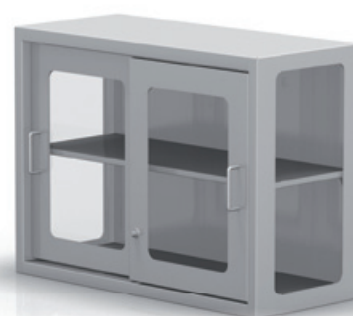

2-289

Wall-mounted medical cabinet

- wall-mounted cabinet made of stainless steel 1.4301 and safety glass
- two glass sliding doors and glass sides
- one fixed stainless steel shelf, totaling two surfaces

	L	S	H
2-289-1	800	350	600
2-289-2	1000	350	600
2-289-3	1200	350	600



2-279

Medical cabinet with electronic locking mechanism

- wall-mounted cabinet made of stainless steel 1.4301 and safety glass
- two glass wing doors with rubber insulation and handles
- door equipped with locking mechanism - opening the door from one side disables opening from the other side
- locking mechanism signals opening/closing via green/red LED lighting which change color upon opening/closing
- one fixed stainless steel shelf, totaling two surfaces
- safe, rounded edges

	L	S	H
2-279-1	620	570	715
2-279-2	720	670	815



2-290

Opened medical cabinet

- self-standing cabinet without door, made of stainless steel 1.4301
- flat table top and one fixed stainless steel shelf, totaling three surfaces
- cabinet with skirting board or on 140 mm legs with leveling adjustment

	L	S	H
2-290-1	450	600	850
2-290-2	600	600	850
2-290-3	800	600	850
2-290-4	1000	600	850
2-290-5	1200	600	850



2-291

Medical cabinet

- self-standing cabinet made of stainless steel 1.4301
- one full wing door
- flat table top and one fixed stainless steel shelf, totaling three surfaces
- cabinet with skirting board or on 140 mm legs with leveling adjustment

	L	S	H
2-291-1	400	600	850
2-291-2	500	600	850
2-291-3	600	600	850



08

MEDICAL
AND STORAGE
CABINETS

ALVO®
MEDICAL



2-292
Medical cabinet

- self-standing cabinet made of stainless steel 1.4301
- double full wing door
- one fixed stainless steel shelf, totaling two surfaces
- cabinet with skirting board or on 140 mm legs with leveling adjustment

	L	S	H
2-292-1	800	600	850
2-292-2	1000	600	850
2-292-3	1200	600	850



2-293
Medical cabinet

- self-standing cabinet made of stainless steel 1.4301
- two full sliding door
- one fixed stainless steel shelf, totaling two surfaces
- cabinet with skirting board or on 140 mm legs with leveling adjustment

	L	S	H
2-293-1	800	600	850
2-293-2	1000	600	850
2-293-3	1200	600	850



2-294
Cabinet for hospital footwear

- self standing cabinet without door made of stainless steel 1.4301
- specifically designed for hospital footwear
- cabinet with skirting board or on 140 mm legs with leveling adjustment

	L	S	H	
2-294-1	600	400	600	4 pairs
2-294-2	850	400	600	6 pairs
2-294-3	1100	400	600	8 pairs
2-294-4	1350	400	600	10 pairs



2-295

Three-drawer standing cabinet

- made of stainless steel 1.4301
- three fully-retractable drawers mounted on telescopic rails with braking function equipped with rubber insulation and handles
- double-walled cabinet front
- honeycomb-like interior construction
- cabinet with skirting board or on 140 mm legs with leveling adjustment
- safe, rounded edges

	L	S	H
2-295-1	400	600	850
2-295-2	500	600	850
2-295-3	600	600	850



2-296

Four-drawer standing cabinet

- made of stainless steel 1.4301
- four fully-retractable drawers mounted on telescopic rails with braking function equipped with rubber insulation and handles
- double-walled cabinet front
- honeycomb-like interior construction
- cabinet with skirting board or on 140 mm legs with leveling adjustment
- safe, rounded edges

	L	S	H
2-296-1	400	600	850
2-296-2	500	600	850
2-296-3	600	600	850



2-299

Standing cabinet with sink

- made of stainless steel 1.4301
- double full wing doors, equipped with rubber insulation and handle
- one sink with plastic siphon on the table top, dimensions: 400 x 400 x 250 mm
- raised back edge of the table top
- honeycomb-like interior construction
- cabinet with skirting board or on 140 mm legs with leveling adjustment
- safe, rounded edges

	L	S	H
2-299-1	800	600	850
2-299-2	1000	600	850
2-299-3	1200	600	850





Graphic elements can be printed on stainless steel or on glass.



ALVO offers a combination of healing design art that is based on the shape of drop. Colors and layout will be custom-designed and visualized to match with the customer's interior.



08

MEDICAL AND STORAGE CABINETS





09

BASKETS, SHELVES
AND TROLLEYS
FOR STERILE
PRODUCTS



ALVO baskets, shelves and trolleys for sterile products are made of high quality stainless steel. They are specially designed for storing and transporting sterile goods.

MAIN FEATURES:

As standard products we offer shelves and containers with different measurements and configurations. The trolleys are equipped with high quality castors with non-smudging wheels.



09

BASKETS, SHELVES
AND TROLLEYS
FOR STERILE
PRODUCTS

ALVO[®]
MEDICAL



2-500

Trolley for transportation of sterile products and dressings

- made of stainless steel 1.4301
- trolley for transportation of six sterilization units
- double wing doors openable on 270°, with rubber insulation and lock
- two shelves inside
- two maneuvering handles, along the shorter sides
- castors with diameter 160 mm, two of them with brakes
- non-smudging wheels

	L	S	H	table top
2-500-1	690	680	1240	800x680
2-500-2	1260	680	1240	1100x680
2-500-3*	680	680	1240	520x680

* single door



2-510

Paper trolley

- made of stainless steel 1.4301
- trolley for paper and fabric transportation and storage
- castors with diameter 80 mm, two of them with brakes
- non-smudging wheels

	L	S	H
2-510	1100	400	1000



2-520

Transport trolley

- made of stainless steel 1.4301
- transport trolley
- loading capacity: 50 kg
- trolley with maneuvering handle, along the shorter side
- castors with diameter 100 mm, two of them with brakes
- non-smudging wheels

	L	S	H
2-520	1080	600	850

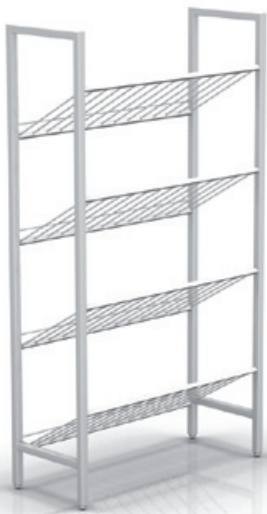

2-720

Shelves for urine bottles and bed pans

- made of stainless steel 1.4301
- self-standing shelf for urine bottles and bedpans
- four diagonally-mounted, metal drying racks
- shelves on 150 mm legs with level adjustment

	L	S	H
2-720-1	1000	400	1800
2-720-2	600	400	1800



4-3702

Hanging shelf for scrub sinks, equipped with drying racks

- wall mounted shelf made of stainless steel 1.4301
- equipped with four diagonally-mounted, metal drying racks
- equipped with drainage trays

	L	S	H
4-3702	600	300	900



2-150

Hook rail wall mounted

- made of stainless steel 1.4301
- two wall mounted hook rails for hanging sterilization baskets, shelves, hangers
- rails without equipment

	L	S	H
2-150-1	-	-	900
2-150-2	-	-	1800



09

BASKETS, SHELVES
AND TROLLEYS
FOR STERILE
PRODUCTS

ALVO®
MEDICAL



2-180
Hook rail mobile

- made of stainless steel 1.4301
- trolley for hanging sterilization baskets, shelves, hangers
- 16 pairs of hooks, eight pairs on each side of trolley
- two maneuvering handles
- castors with diameter 80 mm, two of them with brake

	L	S	H
2-180	530	600	1500

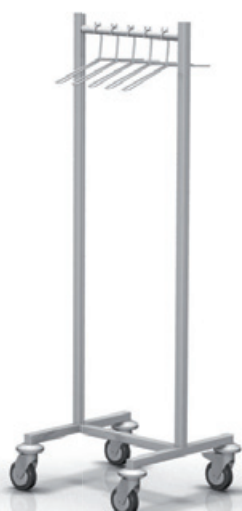

2-182
Portable radiology
apron hanger

- made of stainless steel 1.4301
- equipped with five hangers, specifically designed for radiology aprons
- base mounted on four 80 mm diameter wheels, two of them with brake

	L	S	H
2-182	565	565	1600



2-123
Storage shelves

- shelf made of stainless steel 1.4301 with five full, fixed shelves
- shelves on 140 mm legs with level adjustment

	L	S	H
2-123-1	600	500	1800
2-123-2	1000	500	1800
2-123-3	1200	500	1800

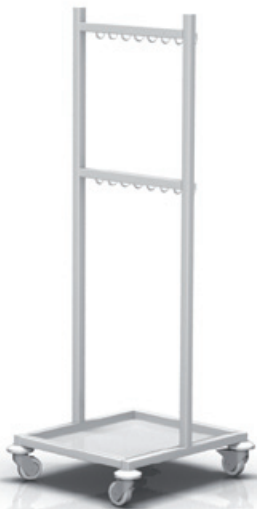

2-162
Tube and OR-tower
holder

- made of stainless steel 1.4301
- base mounted on four 80 mm diameter wheels, two of them with brake

	L	S	H
2-162	530	600	1600

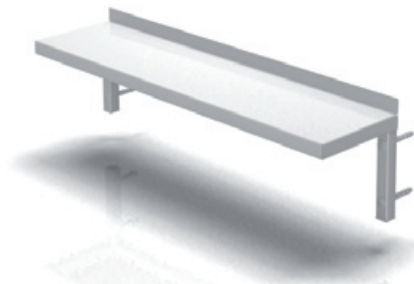

2-120
Shelf

- wall mounted shelf made of stainless steel 1.4301
- upraised back edge on 30 mm

	L	S	H
2-120-1	800	200	230
2-120-2	1000	300	230
2-120-3	1200	350	230



2-121
Shelf

- wall mounted double shelf made of stainless steel 1.4301
- upraised back edge on 30 mm
- distance between shelves 300 mm

	L	S	H
2-121-1	800	300	380
2-121-2	1000	300	380
2-121-3	1200	300	380



09

BASKETS, SHELVES
AND TROLLEYS
FOR STERILE
PRODUCTS

ALVO®
MEDICAL



2-151
Sterile goods basket

- basket made of stainless steel 1.4301 rods

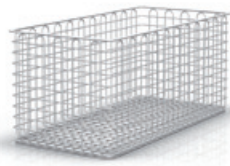

2-152
Sterile goods basket

- basket made of stainless steel 1.4301 rods

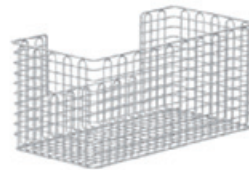

2-153
Sterile goods basket

- basket made of stainless steel 1.4301 rods
- front cut out



2-155
Shelf

- made of stainless steel 1.4301
- shelf with upraised edges

	L	S	H
2-151	575	280	135

	L	S	H
2-152	575	280	265

	L	S	H
2-153	575	280	265

	L	S	H
2-155	580	260	145

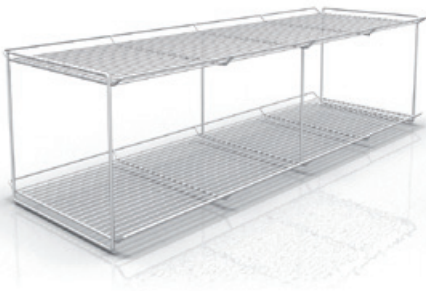

2-156
Double shelf

- made of stainless steel 1.4301 rods

	L	S	H
2-156	580	285	285



2-159
Suture material basket

- made of stainless steel 1.4301

	L	S	H
2-159	590	130	400



2-160
Hanging rail

- made of stainless steel 1.4301
- standard shelf consists in eight hooks; possibility of produce it with different number of hooks

	L	S	H
2-160	580	180	100



09

BASKETS, SHELVES
AND TROLLEYS
FOR STERILE
PRODUCTS

ALVO[®]
MEDICAL



2-161
Shoe holder

- made of stainless steel 1.4301
- holder with hooks for six pairs of shoes
- designed to be wall mounted

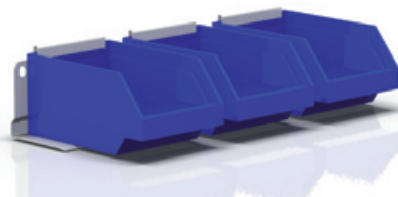

2-165
Hanger for 3
plastic containers

- holder made of stainless steel 1.4301
- containers made of plastic

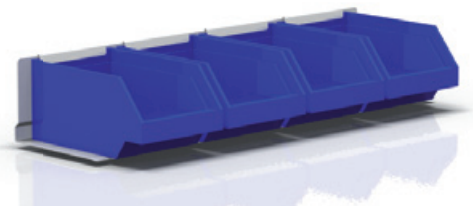

2-166
Hanger for 4
plastic containers

- holder made of stainless steel 1.4301
- containers made of plastic

	L	S	H
2-161	800	180	300

	L	S	H	
2-165	145	225	110	single container
	530	-	-	hanger width

	L	S	H	
2-166	145	225	110	single container
	655	-	-	hanger width

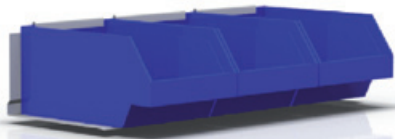

2-167

Hanger for 3 big plastic containers

- holder made of stainless steel 1.4301
- containers made of plastic

	L	S	H	
2-167	200	310	150	single container
	655	-	-	hanger width

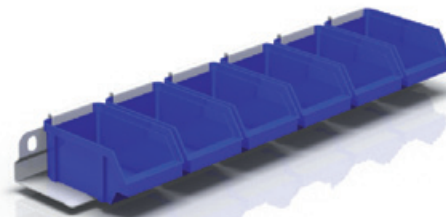

2-168

Hanger for 6 small plastic containers

- holder made of stainless steel 1.4301
- containers made of plastic

	L	S	H	
2-168	76	120	56	single container
	530	-	-	hanger width



09

BASKETS, SHELVES
AND TROLLEYS
FOR STERILE
PRODUCTS





10

MEDICAL
WORKING
TABLES



ALVO working tables are made of the highest quality stainless steel and designed specifically for preparation rooms and other facilities where a lot of work space is needed. The tables can be tailor-made and can include bays, cabinets, drawers and other accessories.



MAIN FEATURES:

As standard products we offer different configurations of tables with plain table tops, table tops with bays, cabinets and drawers. The tables have small plastic legs with level adjustment. There are additional accessories, such as: trap with filters for gypsum, lighted table top, water tap, shower tap, soap and disinfectant dispensers.



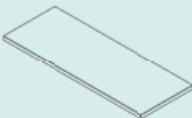
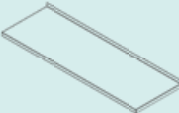
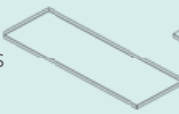
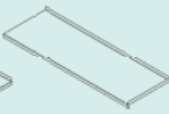
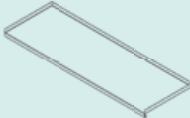
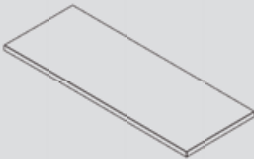
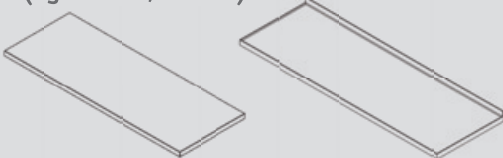
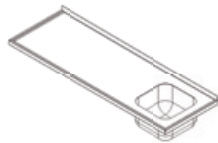

TABLE TOP AND SINK OPTIONS

TYPE OF TABLE TOP	RAISED EDGES
<p>Flat table top made of stainless steel</p>	<p>Flat table top </p>
	<p>Table top with raised back edge </p>
<p>Recessed table top made of stainless steel</p>	<p>Table top with raised back and left or right edges  </p>
	<p>Table top with raised back and both side edges </p>
<p>Laminated table top</p> 	<p>above options are achieved by adding a material strip</p>
<p>Flat and recessed table top made of mineral composite materials (eg. Corian, Staron)</p> 	<p>above options are achieved by adding a material strip</p>
<p>Table top made of Trespa</p> 	<p>above options are achieved by adding a material strip</p>

SINK * * * * *

Sink 400 x 400 x 250



Sink 400 x 340 x 200

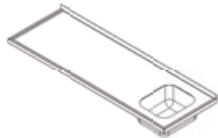

Sink Ø340 x 170



Custom sized under request

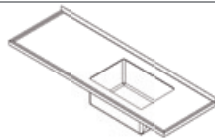

Stainless steel sink installed embedded in the table top

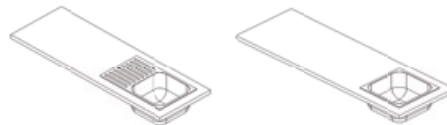

Ceramic sink installed built-in the table top

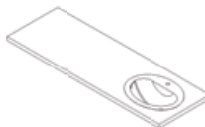

Stainless steel or ceramic sink installed embedded in the table top

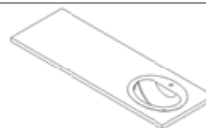

Sink made of the same material of the table top

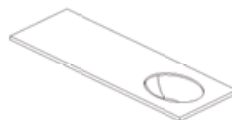

Stainless steel or ceramic sink installed embedded in the table top

* the sinks can be installed in the right or left side of the table top
 ** the number and kind of sinks can vary in function of the end-users' needs
 *** the water tap can be installed in the wall or in the table top itself

10

MEDICAL
WORKING
TABLES

ALVO®
MEDICAL



2-360

Table with lighted table top

- made of stainless steel 1.4301
- with lighted table top for testing of sterile units
- base mounted on 140 mm adjustable legs

	L	S	H
2-360-1	1400	600	850
2-360-2	1400	900	850



2-370

Table for plaster bands preparation

- made of stainless steel 1.4301
- with one bay with gypsum clarifier
- bay dimensions: 450x450x150 mm
- upraise table top edges
- base mounted on 140 mm adjustable legs

	L	S	H
2-370-1	1400	600	850
2-370-2	1600	600	850



2-371

Table for plaster bands preparation

- made of stainless steel 1.4301
- with one bay with gypsum clarifier
- bay dimensions: 450x450x150 mm
- one full, wing door cabinet
- upraise table top edges
- base mounted on 140 mm adjustable legs

	L	S	H
2-371-1	1400	600	850
2-371-2	1600	600	850



2-380

Working table

- made of stainless steel 1.4301
- upraised back edge on 40 mm
- base mounted on 140 mm adjustable legs

	L	S	H
2-380-1	400	600	850
2-380-2	500	600	850
2-380-3	600	600	850
2-380-4	800	600	850
2-380-5	1000	600	850
2-380-6	1200	600	850
2-380-7	1400	600	850



2-381
Working table

- made of stainless steel 1.4301
- upraised back edge on 40 mm
- one fixed shelf situated 140 mm above floor
- base mounted on 140 mm adjustable legs

	L	S	H
2-381-1	400	600	850
2-381-2	500	600	850
2-381-3	600	600	850
2-381-4	800	600	850
2-381-5	1000	600	850
2-381-6	1200	600	850
2-381-7	1400	600	850



2-382
Working table

- made of stainless steel 1.4301
- upraised back edge of the table top on 40 mm
- cabinet with full, wing door under table top
- base mounted on 140 mm adjustable legs

	L	S	H
2-382-1	1000	600	850
2-382-2	1200	600	850
2-382-3	1400	600	850



2-383
Working table

- made of stainless steel 1.4301
- upraised back edge of the table top on 40 mm
- three drawers under the table top
- base mounted on 140 mm adjustable legs

	L	S	H
2-383-1	1000	600	850
2-383-2	1200	600	850
2-383-3	1400	600	850



10

MEDICAL
WORKING
TABLES

ALVO®
MEDICAL



2-390 | 2-391
Working table

- made of stainless steel 1.4301
- back edge of table upraised to 40 mm
- sink with plastic siphon on one side of the table top; dimensions: 400x400x250 mm
- masking frame in front under table top, height 250 mm
- base mounted on 140 mm adjustable legs

	L	S	H
2-390-1	800	600	850
2-390-2	1000	600	850
2-390-3	1200	600	850
2-390-4	1400	600	850



2-392
Working table

- made of stainless steel 1.4301
- bay with plastic siphon in one side of the table top; dimensions: 400x400x250 mm
- full, wing door cabinet with one fixed shelf in the interior
- upraise back edge to 40 mm
- masking frame in front under table top, height 250 mm
- base mounted on 140 mm adjustable legs

	L	S	H
2-392-1	1000	600	850
2-392-2	1200	600	850
2-392-3	1400	600	850



2-393
Working table

- made of stainless steel 1.4301
- bay with plastic siphon in one side of the table top; dimensions: 400x400x250 mm
- three drawers under the table top
- upraise back edge to 40 mm
- masking frame in front under table top, height 250 mm
- base mounted on 140 mm adjustable legs

	L	S	H
2-393-1	1000	600	850
2-393-2	1200	600	850
2-393-3	1400	600	850



2-394
Working table

- made of stainless steel 1.4301
- bay with plastic siphon in one side of the table top; dimensions: 400x400x250 mm
- three drawers under the table top and one full, wing cabinet door
- upraise back edge to 40 mm
- masking frame in front under table top, height 250 mm
- base mounted on 140 mm adjustable legs

	L	S	H
2-394	1400	600	850



2-395
Working table

- made of stainless steel 1.4301
- table with two bays
- back edge of table upraised to 40 mm
- bays with plastic siphon; dimensions: 400 x 400 x 250 mm
- masking frame in front under table top, height 250 mm
- cabinet base mounted on 140 mm adjustable legs

	L	S	H
2-395-1	1000	600	850
2-395-2	1200	600	850
2-395-3	1400	600	850



2-396
Working table

- made of stainless steel 1.4301
- table with one bay with plastic siphon; depth 300 mm
- back edge of table upraised to 40 mm
- masking frame in front under table top, height 300 mm
- cabinet base mounted on 140 mm adjustable legs

	L	S	H
2-396-1	800	600	850
2-396-2	1000	600	850
2-396-3	1200	600	850
2-396-4	1400	600	850



10

MEDICAL
WORKING
TABLES

ALVO[®]
MEDICAL



2-397 Nurses' station counters

The nurses' stations not only carry out administrative tasks, but also clinically associated functions that have impact on the patient care conditions. ALVO provides adapted solutions for the nurses counters, configuring the space with the ergonomics and design in mind. Thanks to the wide range of cabinets and drawers, the counters can be designed specifically for each station. Nature-inspired graphics printed on the outer side of the counter (either made of steel or glass) create healing and soothing atmosphere in the intensive care units, emergency departments, hospital waiting areas.



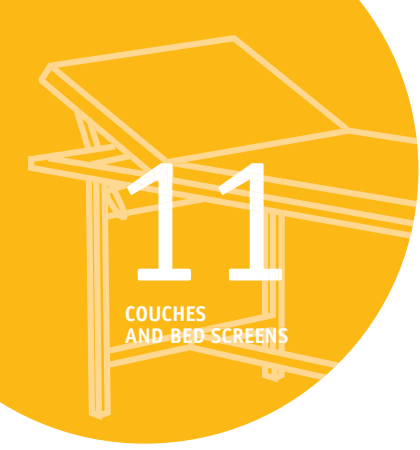

ALVO couches and bed screens are made of the highest quality materials. The structure of the couches and bed screens are made of stainless steel. The couches upholstery and material used in screens are resistant to disinfectants used in hospitals.

MAIN FEATURES:

Standard color for couches and screens is green, additional colors upon request.





2-061
Examination couch

- made of stainless steel and high quality upholstery fabric resistant to disinfectants
- two section couch, with head-rest adjustment, in range of 30°
- standard color is green; other colors available: page 112
- couch with level adjustment
- permissible load: 160 kg

	L	S	H
2-061	1950	650	700



2-062
Examination couch

- made of stainless steel and high quality upholstery fabric resistant to disinfectants
- two section couch with head rest and foot rest adjustment
- head rest adjusted manually in range of 30°, foot rest adjusted manually in range of 10°
- standard color is green; other colors available: page 112
- movable side barriers
- couch on castors with diameter 100 mm, two of them with brake
- castors with non-smudging wheels
- permissible load: 160 kg

	L	S	H
2-062	1950	760	700

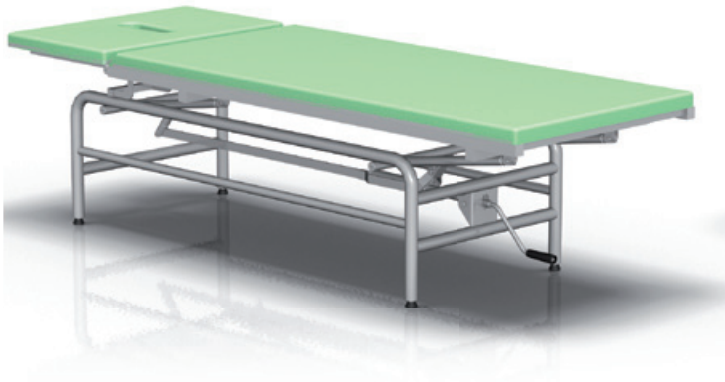

2-063
Examination and massage couch

- made of stainless steel and high quality upholstery fabric resistant to disinfectants
- two section couch with height and head rest adjustment
- couch height adjusted by crank in range of 530-850 mm
- head rest adjusted manually in range of 0°-45°
- head rest with hole for easy breathing during massage
- standard color is green; other colors available: page 112
- couch with level adjustment

	L	S	H
2-063	1950	680	530/850



2-065
Washing couch

- made of stainless steel and high quality upholstery fabric resistant to disinfectants
- table with rubber washing tub with drain
- hydraulic height adjustment by foot lever in range 540-850 mm
- movable side barriers
- couch on castors with diameter 125 mm, two of them with brakes
- dimensions of mattress: 1950x600
- permissible load: 160 kg

	L	S	H	Mattress
2-065-1	2130	780	780/1070	1950 x 600
2-065-2	2130	780	780/1070	1950 x 660





2-064
Baby examination cabinet

- made of stainless steel and high quality upholstery fabric resistant to disinfectants
- cabinet with soft, upholstered table top, table top dimensions: 1100x600 mm
- table top with electronic scale, capacity 30 kg and measure
- cabinet with one shelf and three drawers under table top
- table top height: 980 mm

	L	S	H
2-064	1280	600	1150



2-070
Washable folding screen

- base mounted on 50 mm wheels, two of them with brakes
- frame made of stainless steel 1.4301
- non-smudging wheels

Orion Washable Fabric

Orion is a chenille, upholstery fabric with high abrasion-resistance (>90,000 cycles). This special formula allows for easy removal of both liquid and solid stains. To remove stains, apply gentle, circular motions and allow to air dry. Orion fabric can be ironed and hand-washed at low temperatures. 100% polyester

Porto Washable Fabric

Porto is a washable, woven fabric. Porto prevents the absorption of fluids and eliminates the collection of liquid contaminants. Porto offers a high degree of abrasion-resistance, enables easy cleaning without the use of detergents, and is safe for washing and ironing. Despite being a woven fabric, fibers are extremely fine making Porto soft to the touch. 100% polyester

	L	S	H	
2-070-1	1000	600	1880	one screen
2-070-2	2000	600	1880	two screens
2-070-3	3000	600	1880	three screens



2-943
Infusion holder for couches

- stand with two hooks for infusions
- made of stainless steel 1.4301

	L	S	H
2-943	1300	-	-

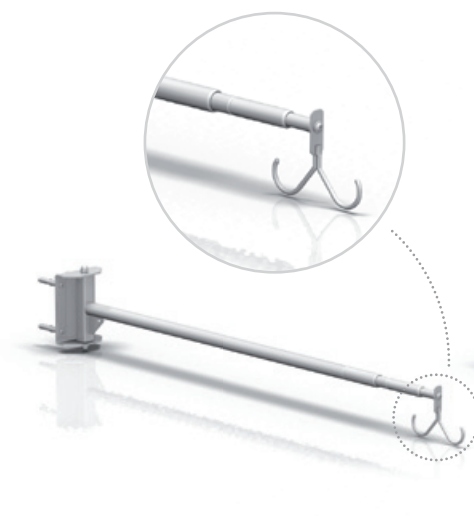

2-071
Telescopic extension arm

- wall mounted telescopic extension arm with hooks for two drip bottles
- medical attested cloth, standard color is green
- cloth dimensions: 2000x1500 mm

	L	S	H
2-071	880/2060	-	-

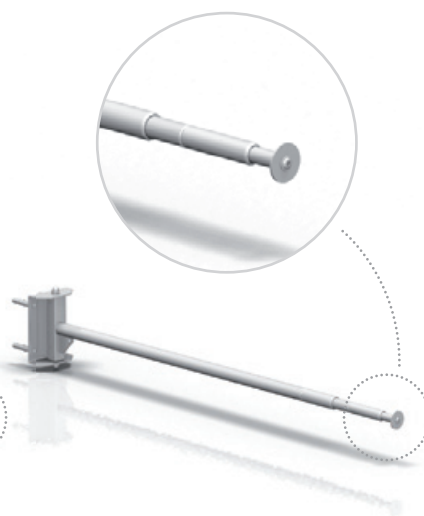

2-072
Telescopic extension arm

- wall mounted telescopic extension arm
- medical attested cloth, standard color is green
- cloth dimensions: 2000x1500 mm

	L	S	H
2-072	880/2060	-	-



2-980
Holder for paper towels
for couches

- made of stainless steel 1.4301

	L	S	H
2-980	630	125	-





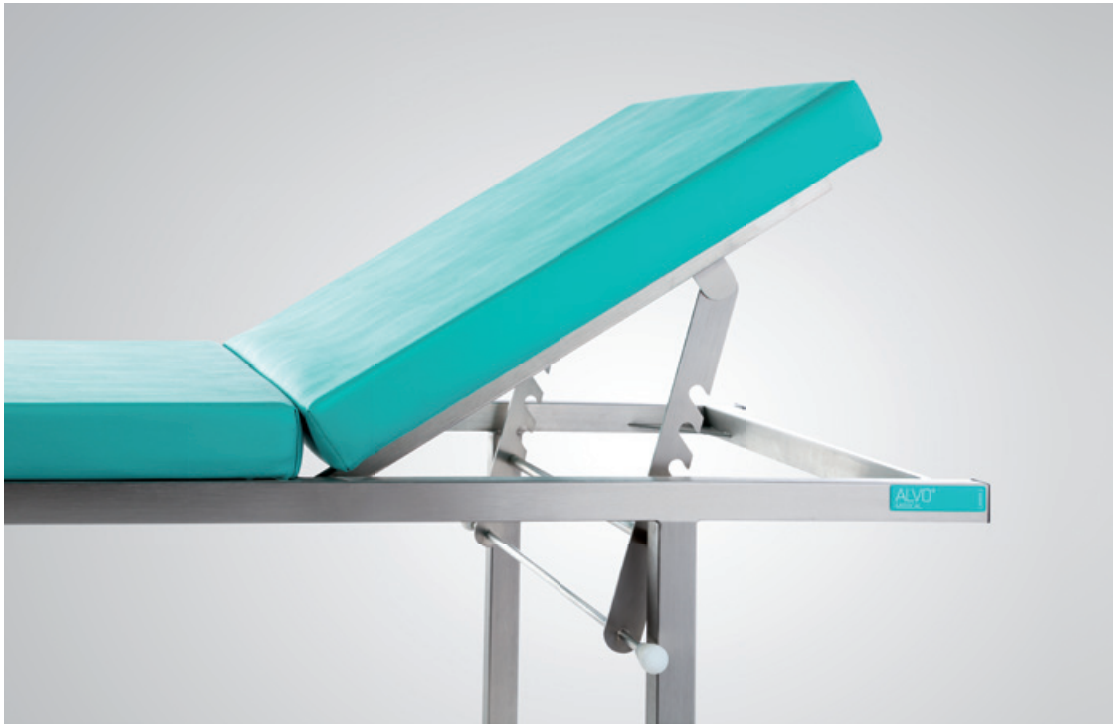



Following the philosophy of Design that heals, while meeting the customers' requirements, ALVO offers wide range of options for customization of each product. Colors of the furnishing systems provided by ALVO Medical can be chosen from the standard RAL palette.

The colours **orange** or **pink** are recommended for maternity wards, but not recommended for dermatology departments, as those colors tend to make patients feel itchy.

A **blue** and **green** palette is recommended for ORs, where the eyes of the clinicians are focused on the red spots of blood. These colours are on the opposite spectrum of the colour wheel to the red colour, which makes it more relaxing on the doctor's vision.

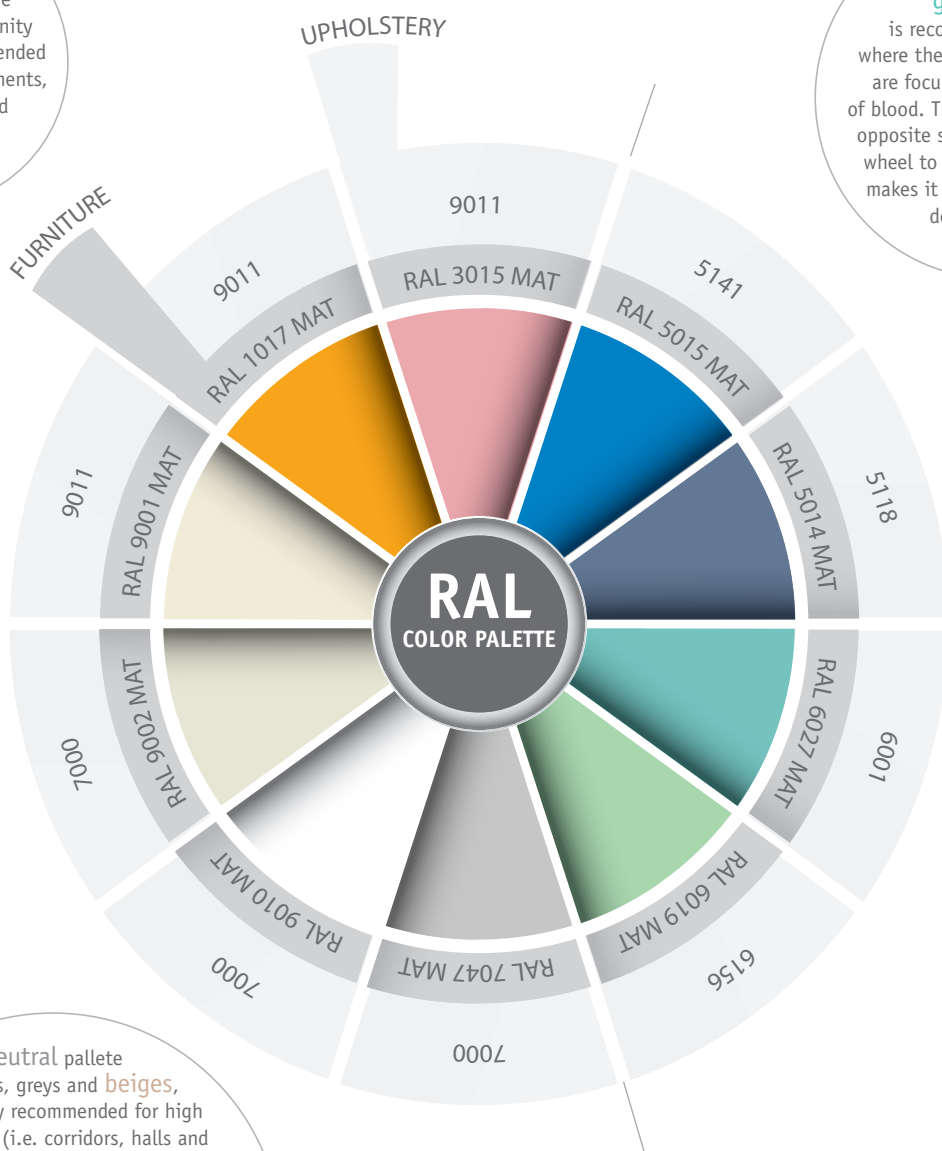

Neutral palette of whites, greys and **beiges**, is especially recommended for high traffic areas (i.e. corridors, halls and waiting rooms), since they are light and clear. Even though, when used in a corridor, some contrast as a guide is needed, since the total absence of colour can create a visual hazard for older people with reduced visual acuity, and even other patients with compromised equilibrium. For those areas, it is recommended to place artworks, coloured fittings (i.e. hand rails, doors, etc.) among the wall panels.

Certificates

ALVO holds a certified quality management system according to [EN ISO 9001:2008](#) and [EN ISO 13485:2003+AC:2009](#) for design and development, production, installation and servicing of patient handling devices, related accessories and retractor systems.

We introduced **Quality Management System** for medical devices, in order to ensure top quality at every stage of the manufacturing process, from design through plans and specifications, materials and production methods used, to the final control stage of the ready-made product.

Hygiene

ALVO's cooperation with [IGP Pulvertechnik](#) and [Sanitized[®]](#) results in the best antimicrobial protection on all powder coated medical equipment.

Hygiene is of key importance in the operating theatre. The silver ion-based antibacterial treatment by [Sanitized[®]](#) is incorporated in the most demanding surfaces of the ALVO products in order to permanently and reliably protect them against the growth of bacteria such as staphylococcus aureus and echeria coli.

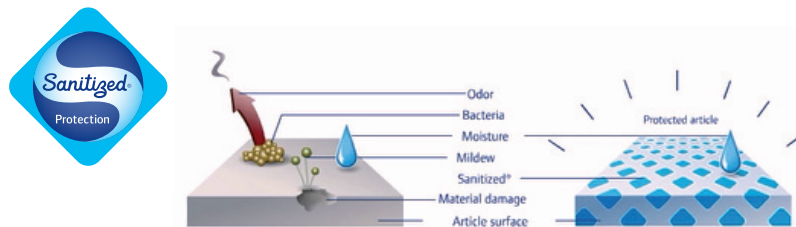

Antimicrobial copper Cu+

Antimicrobial Copper surfaces are the most effective antimicrobial touch surface and are ideal for the healthcare environment where their inherent, continuous ability to kill bacteria will supplement infection control measures. ALVO Medical provides medical furniture and other products with antimicrobial copper touch surfaces. With different finishes, the line of products adapts to the hospital needs.

The line includes mayo and instrument tables, and other products with antimicrobial fittings and handles, such as cabinets, anesthesia and emergency trolleys, and treatment trolleys.



ALVO Sp. z o.o. Sp.k.
ul. Południowa 21a
64-030 Śmigiel, Poland
tel. +48 65 518 98 49
fax +48 65 518 98 56
www.alvo.pl

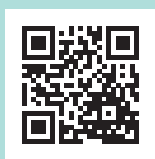

Management
System
ISO 13485:2003
ISO 9001:2008
www.tuv.com
ID 0000025088



WAARDENBURG
MEDICAL

Dorpsstraat 8a
4181 BN Waardenburg

www.waardenburgmedical.com
info@waardenburgmedical.com

+31(0) 418 651 078
+31(0) 61066 2894